

2017-2018

# Intermediate Energy Infobook

A comprehensive classroom resource containing fact sheets that introduce students to energy, and describe energy sources, electricity, consumption, efficiency, conservation, transportation, climate change, and emerging technologies. The Infobooks can be used as a resource for many energy activities.



## Grade Level:

**Int** Intermediate

## Subject Areas:



Science



Social Studies



Math



Language Arts



Technology



## Teacher Advisory Board

**Constance Beatty**  
Kankakee, IL

**Barbara Lazar**  
Albuquerque, NM

**James M. Brown**  
Saratoga Springs, NY

**Robert Lazar**  
Albuquerque, NM

**Amy Constant - Schott**  
Raleigh, NC

**Leslie Lively**  
Porters Falls, WV

**Nina Corley**  
Galveston, TX

**Jennifer Mitchell -  
Winterbottom**  
Pottstown, PA

**Shannon Donovan**  
Greene, RI

**Mollie Mukhamedov**  
Port St. Lucie, FL

**Linda Fonner**  
New Martinsville, WV

**Don Pruett Jr.**  
Sumner, WA

**Samantha Forbes**  
Vienna, VA

**Judy Reeves**  
Lake Charles, LA

**Michelle Garlick**  
Long Grove, IL

**Tom Spencer**  
Chesapeake, VA

**Erin Gockel**  
Farmington, NY

**Jennifer Trochez  
MacLean**  
Los Angeles, CA

**Robert Griegoliet**  
Naperville, IL

**Wayne Yonkelowitz**  
Fayetteville, WV

**Bob Hodash**  
Bakersfield, CA

**DaNel Hogan**  
Tucson, AZ

**Greg Holman**  
Paradise, CA

## NEED Mission Statement

The mission of The NEED Project is to promote an energy conscious and educated society by creating effective networks of students, educators, business, government and community leaders to design and deliver objective, multi-sided energy education programs.

## Permission to Copy

NEED curriculum is available for reproduction by classroom teachers only. NEED curriculum may only be reproduced for use outside the classroom setting when express written permission is obtained in advance from The NEED Project. Permission for use can be obtained by contacting [info@need.org](mailto:info@need.org).

## Teacher Advisory Board

In support of NEED, the national Teacher Advisory Board (TAB) is dedicated to developing and promoting standards-based energy curriculum and training.

## Energy Data Used in NEED Materials

NEED believes in providing teachers and students with the most recently reported, available, and accurate energy data. Most statistics and data contained within this guide are derived from the U.S. Energy Information Administration. Data is compiled and updated annually where available. Where annual updates are not available, the most current, complete data year available at the time of updates is accessed and printed in NEED materials. To further research energy data, visit the EIA website at [www.eia.gov](http://www.eia.gov).



1.800.875.5029

[www.NEED.org](http://www.NEED.org)

© 2017



Printed on Recycled Paper



# Intermediate Energy Infobook

## Table of Contents

▪ Standards Correlation Information	4
▪ NEED Intermediate Curriculum Resources	5
▪ Introduction to Energy	6
▪ Biomass	8
▪ Coal	10
▪ Geothermal	12
▪ Hydropower	14
▪ Natural Gas	16
▪ Petroleum	18
▪ Propane	20
▪ Solar	22
▪ Uranium (Nuclear)	24
▪ Wind	26
▪ Climate Change	28
▪ Hydrogen	30
▪ Electricity	32
▪ Measuring Electricity	39
▪ History of Electricity	42
▪ Facts of Light	44
▪ Energy Consumption	45
▪ Energy Efficiency	50
▪ Glossary	54





# Standards Correlation Information

[www.NEED.org/curriculumcorrelations](http://www.NEED.org/curriculumcorrelations)

## Next Generation Science Standards

- This guide effectively supports many Next Generation Science Standards. This material can satisfy performance expectations, science and engineering practices, disciplinary core ideas, and cross cutting concepts within your required curriculum. For more details on these correlations, please visit NEED's curriculum correlations website.

## Common Core State Standards

- This guide has been correlated to the Common Core State Standards in both language arts and mathematics. These correlations are broken down by grade level and guide title, and can be downloaded as a spreadsheet from the NEED curriculum correlations website.

## Individual State Science Standards

- This guide has been correlated to each state's individual science standards. These correlations are broken down by grade level and guide title, and can be downloaded as a spreadsheet from the NEED website.

The screenshot shows the NEED website interface. At the top left is the NEED logo with the text "National Energy Education Development Project". To the right are social media icons for Facebook, Twitter, Instagram, Pinterest, LinkedIn, and YouTube. Below these is a search bar with the text "Search this site:". A navigation menu contains links for "About NEED", "Educators", "Students", "Partners", "Youth Awards", "Contact", and "Shop". On the left side, there is a vertical menu with dropdown arrows for "Curriculum Resources", "Professional Development", "Evaluation", "Supplemental Materials", "Curriculum Correlations", and "Distinguished Service and Bob Thompson Awards". The main content area is titled "> Educators > Curriculum Correlations" and "Curriculum Correlations". Below the title, there is a paragraph explaining that NEED has correlated materials to the Disciplinary Core Ideas of the Next Generation Science Standards, the Common Core State Standards for English/Language Arts and Mathematics, and each state's individual science standards. It notes that most files are in Excel format and recommends downloading them. Below this paragraph is a list of links: "Navigating the NGSS? We have What You NEED!", "NEED alignment to the Next Generation Science Standards", "Common Core State Standards for English and Language Arts", "Common Core Standards for Mathematics", and a list of states: Alabama, Alaska, Arizona, Arkansas, and California. On the bottom left of the screenshot, there is a green calendar icon and a snippet of text: "NEED is adding new energy workshops all the time. Want to".





# NEED Intermediate Curriculum Resources

For more in-depth information, inquiry investigations, and engaging activities, download these curriculum resources from [www.NEED.org](http://www.NEED.org).

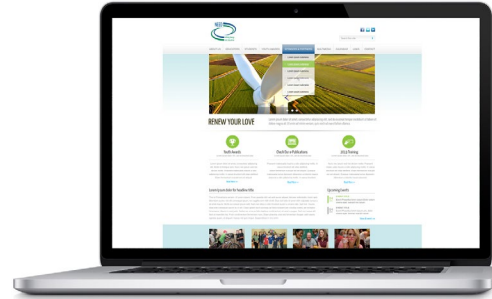

<b>INTRODUCTORY ACTIVITIES</b>	Energy Games and Icebreakers Energy Polls
<b>STEP ONE: Science of Energy</b>	Energy Flows Energy Works Intermediate Science of Energy
<b>STEP TWO: Sources of Energy</b>	Energy Enigma Energy Expos Energy from the Sun Energy from the Wind Energy from Uranium Energy Games and Icebreakers Energy of Moving Water Energy on Public Lands Exploring Ocean Energy and Resources Exploring Oil and Natural Gas Fossil Fuels to Products Great Energy Debate H <sub>2</sub> Educate Intermediate Energy Infobook Activities Schools Going Solar Understanding Coal U.S. Energy Geography Wind for Schools
<b>STEP THREE: Electricity and Magnetism</b>	Current Energy Affair Electroworks Energy Games and Icebreakers Intermediate Energy Infobook Activities Smart Meters
<b>STEP FOUR: Transportation</b>	Energy Expos Energy on the Move Exploring Hybrid Buses H <sub>2</sub> Educate Transportation Fuels Debate Transportation Fuels Enigma Transportation Fuels Live!

<b>STEP FIVE: Efficiency and Conservation</b>	Building Science Energy Conservation Contract Energy Expos Energy Games and Icebreakers Energy House Learning and Conserving Monitoring and Mentoring Museum of Solid Waste and Energy Plug Loads Saving Energy at Home and School Understanding Climate Change
<b>STEP SIX: Synthesis and Reinforcement</b>	Digital Energy Energy Analysis Energy and Our Rivers Energy Around the World Energy Carnival Energy Games and Icebreakers Energy Jeopardy Energy Live! Energy Math Challenge Energy on Stage Global Trading Game Greek Mythology and Energy Mystery World Tour NEED Songbook This Mine of Mine Yesterday in Energy
<b>STEP SEVEN: Evaluation</b>	Energy Polls Question Bank
<b>STEP EIGHT: Student Leadership and Outreach</b>	Youth Awards Program Guide



# Introduction to Energy

## What Is Energy?

**Energy** makes change; it does things for us. It moves cars along the road and boats over the water. It bakes a cake in the oven and keeps ice frozen in the freezer. It plays our favorite songs and lights our homes. Energy makes our bodies grow and allows our minds to think. Scientists define energy as the ability to do work.

## Forms of Energy

Energy is found in different forms, such as light, heat, sound, and motion. There are many forms of energy, but they can all be put into two categories: potential and kinetic.

### POTENTIAL ENERGY

**Potential energy** is stored energy and the energy of position, or gravitational potential energy. There are several forms of potential energy.

▪ **Chemical energy** is energy stored in the bonds of **atoms** and **molecules**. It is the energy that holds these particles together. Biomass, petroleum, natural gas, propane, and the foods we eat are examples of stored chemical energy.

▪ **Elastic energy** is energy stored in objects by the application of a force. Compressed springs and stretched rubber bands are examples of elastic energy.

▪ **Nuclear energy** is energy stored in the nucleus of an atom; it is the energy that holds the nucleus together. The energy can be released when the nuclei are combined or split apart. Nuclear power plants split the nuclei of uranium atoms in a process called **fission**. The sun combines the nuclei of hydrogen atoms in a process called **fusion**.

▪ **Gravitational potential energy** is the energy of position or place. A rock resting at the top of a hill contains gravitational potential energy because of its position. Hydropower, such as water in a reservoir behind a dam, is an example of gravitational potential energy.

### KINETIC ENERGY

**Kinetic energy** is motion; it is the motion of waves, **electrons**, atoms, molecules, substances, and objects.

▪ **Electrical energy** is the movement of electrons. Everything is made of tiny particles called atoms. Atoms are made of even smaller particles called electrons, protons, and neutrons. Applying a force can make some of the electrons move. Electrons moving through a wire are called **electricity**. Lightning is another example of electrical energy.

▪ **Radiant energy** is **electromagnetic** energy that travels in vertical (transverse) waves. Radiant energy includes visible light, x-rays, gamma rays, and radio waves. Solar energy is an example of radiant energy.

## Forms of Energy

### POTENTIAL

Chemical Energy



Elastic Energy



Nuclear Energy



Gravitational Potential Energy



### KINETIC

Electrical Energy



Radiant Energy



Thermal Energy



Motion Energy



Sound Energy



▪ **Thermal energy**, or heat, is the internal energy in substances; it is the vibration and movement of the atoms and molecules within a substance. The more thermal energy in a substance, the faster the atoms and molecules vibrate and move. Geothermal energy is an example of thermal energy.

▪ **Motion energy** is the movement of objects and substances from one place to another. Objects and substances move when an unbalanced force is applied according to **Newton's Laws of Motion**. Wind is an example of motion energy.

▪ **Sound energy** is the movement of energy through substances in longitudinal (compression/rarefaction) waves. Sound is produced when a force causes an object or substance to vibrate; the energy is transferred through the substance in a longitudinal wave.

## Conservation of Energy

Your parents may tell you to conserve energy. "Turn off the lights," they say. To scientists, **energy conservation** is not just about saving energy. The **Law of Conservation of Energy** says that energy is neither created nor destroyed. When we use energy, it doesn't disappear. We change one form of energy into another.

A car engine burns gasoline, converting the chemical energy in gasoline into motion energy. Solar cells change radiant energy into electrical energy. Energy changes form, but the total amount of energy in the universe stays the same.

## Efficiency

**Energy efficiency** is the amount of useful energy you get from a system. A perfect, energy efficient machine would change all the energy put in it into useful work—a technological impossibility today. Converting one form of energy into another form always involves a loss of usable energy.

Most energy transformations are not very efficient. The human body is a good example of this. Your body is like a machine, and the fuel for your machine is food. Food gives you the energy to move, breathe, and think.

Your body isn't very efficient at converting food into useful work. Most of the energy in your body is transformed and released as thermal energy (heat). You can really feel that heat when you exercise! This is very much like most energy transfers. The loss of useable energy is often in the form of thermal energy (heat).

## Sources of Energy

We use many different energy sources to do work for us. They are classified into two groups—renewable and nonrenewable.

In the United States, most of our energy comes from **nonrenewable** energy sources. Coal, natural gas, petroleum, propane, and uranium are nonrenewable energy sources. They are used to make electricity, heat our homes, move our cars, and manufacture all kinds of products. These energy sources are called nonrenewable because their supplies are limited. Petroleum, a **fossil fuel**, for example, was formed hundreds of millions of years ago from the remains of ancient sea plants and animals. We can't make more petroleum deposits in a short time.

**Renewable** energy sources include biomass, geothermal energy, hydropower, solar energy, and wind energy. They are called renewable because they are replenished in a short time. Day after day, the sun shines, the wind blows, and the rivers flow. We use renewable energy sources mainly to make electricity.

## Electricity

Electricity is different from the other energy sources because it is a **secondary source of energy**. We must use another energy source to produce electricity. In the U.S., coal is the number one energy source used for generating electricity.

Electricity is sometimes called an **energy carrier** because it is an efficient and safe way to move energy from one place to another, and it can be used for so many tasks. As we use more technology, the demand for electricity grows.

## Energy Transformations

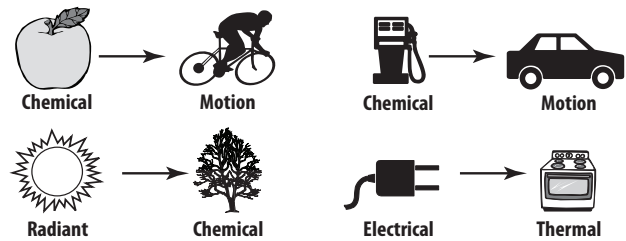

## U.S. Energy Consumption by Source, 2015

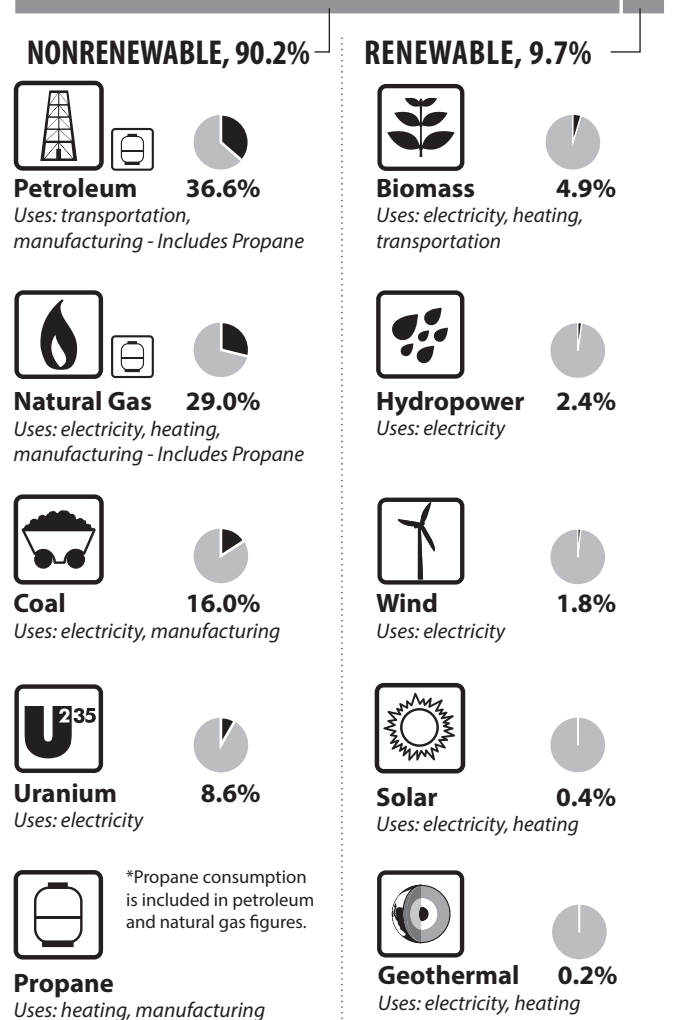

Data: Energy Information Administration  
 \*\*Total does not equal 100% due to independent rounding.



# Biomass

## What Is Biomass?

**Biomass** is any **organic** matter that can be used as an energy source. Wood, crops, and yard and animal waste are examples of biomass. People have used biomass longer than any other energy source. For thousands of years, people have burned wood to heat their homes and cook their food.

Biomass gets its energy from the sun. Plants absorb sunlight in a process called **photosynthesis**. With sunlight, air, water, and nutrients from the soil, plants make sugars called **carbohydrates**. Foods that are rich in carbohydrates (like spaghetti) are good sources of energy for the human body. Biomass is called a **renewable** energy source because we can grow more in a short period of time.

## Use of Biomass

Until the mid-1800s, wood gave Americans 90 percent of the energy they used. Today, biomass provides us almost five percent of the energy we use. It has been replaced by coal, natural gas, petroleum, and other energy sources.

There are many sources of biomass used in the U.S. today. Two sources, wood and **biofuels**, make up the majority of consumption. Other biomass sources include crops, garbage, landfill gas, and by-products from agriculture.

Industry is the biggest biomass consumer today; it uses 48.2 percent of biomass to make products. The transportation sector uses 28.5 percent of biomass by consuming **ethanol** and other biofuels. Power companies use biomass to produce electricity. Almost 12 percent of biomass is used to generate electricity today.

Homes and businesses are the third biggest users; about one in ten homes burn wood in fireplaces and stoves for additional heat. Less than three percent use wood as their main heating fuel. Most use a source other than wood for heating.

In the future, plants may be grown to fuel power plants. Farmers may also have huge farms of energy crops to produce ethanol and other biofuels for transportation.

## Biomass and the Environment

Biomass can pollute the air when it is burned, though not as much as fossil fuels. Burning biomass fuels does not produce pollutants like sulfur, which can cause **acid rain**.

Growing plants for biomass fuel may help to reduce greenhouse gases, since plants use **carbon dioxide** and produce oxygen as they grow. Carbon dioxide is considered an important **greenhouse gas**.

## Photosynthesis

In the process of photosynthesis, plants convert radiant energy from the sun into chemical energy in the form of glucose (or sugar).

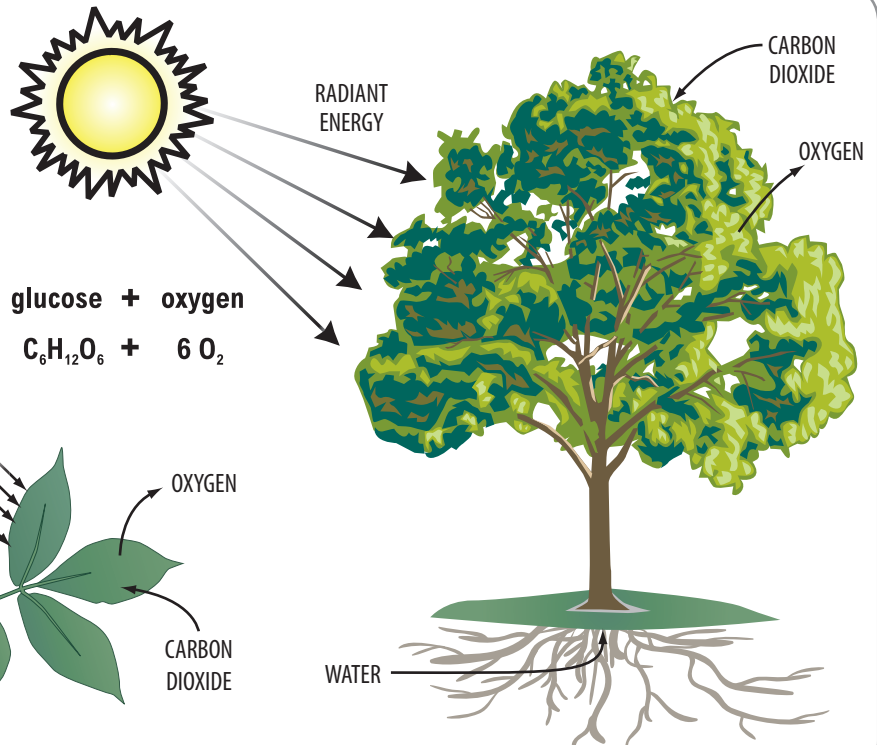
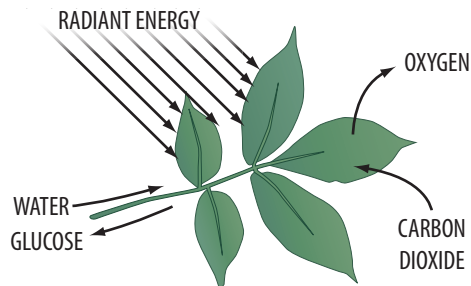

Data: Energy Information Administration

## Using Biomass Energy

A log does not give off energy unless you do something to it. Usually, wood is burned to make heat. Burning is not the only way to use biomass energy, though. There are four ways to release the energy stored in biomass: burning, bacterial decay, **fermentation**, and conversion to gas/liquid fuel.

### ▪ Burning

Wood was the biggest energy provider in the United States and the rest of the world until the mid-1800s. Wood heated homes and fueled factories. Today, wood supplies only a little of our country's energy needs. Wood is not the only biomass that can be burned. Wood shavings, fruit pits, manure, and corn cobs can all be burned for energy.

Garbage is another source of biomass. Garbage can be burned to generate steam and electricity. Power plants that burn garbage and other waste for energy are called **waste-to-energy plants**. These plants are a lot like coal-fired plants. The difference is the fuel. Garbage doesn't contain as much heat energy as coal. It takes about 900 kilograms (2,000 pounds) of garbage to equal the heat energy in 225 kilograms (500 pounds) of coal.

Sometimes, fast-growing crops like sugar cane are grown especially for their energy value. Scientists are also researching ways to grow aquatic plants like seaweed and algae for their energy value.

### ▪ Bacterial Decay

Bacteria feed on dead plants and animals. As the plants and animals decay, they produce a colorless, odorless gas called **methane**. Methane gas is rich in energy. Methane is the main ingredient in natural gas, the gas we use in our furnaces and stoves. Methane is a good energy source. We can burn it to produce heat or to generate electricity.

In some landfills, wells are drilled into the piles of garbage to capture methane produced from the decaying waste. The methane can be purified and used as an energy source, just like natural gas.

### ▪ Fermentation

We can add yeast (a fungus) to biomass to produce an alcohol called ethanol. For centuries, people have fermented crops to make alcoholic drinks like beer and wine. Wine is fermented from grapes. Wheat, corn, grasses, and many other crops can be used to make ethanol.

Ethanol is sometimes made from corn to produce a motor fuel. Automobile pioneer Henry Ford wanted to use ethanol to power his cars instead of gasoline. Ethanol is more expensive to use than gasoline. Usually, it is mixed with gasoline to produce a fuel called E-10, which is 90 percent gasoline and 10 percent ethanol. For cars to run on a higher percentage of ethanol, their engines would have to be changed. But cars can run on E-10 without changes. Adding ethanol to gasoline lowers carbon dioxide emissions.

### ▪ Conversion

**Conversion** means changing a material into something else. Today, we can convert biomass into gas and liquid fuels. We do this by adding heat or chemicals to the biomass. The gas and liquid fuels can then be burned to produce heat or electricity, or it can be used as a fuel for automobiles. In India, cow manure is converted to methane gas to provide heat and light.

## U.S. Sources of Biomass, 2015

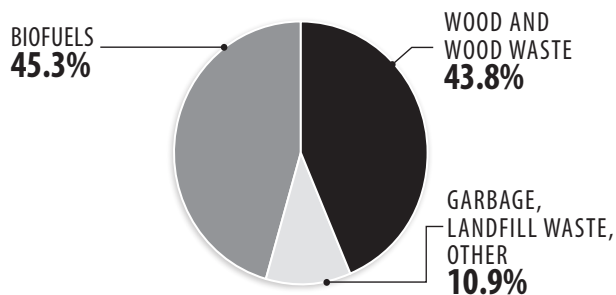

Data: Energy Information Administration

## U.S. Biomass Consumption by Sector, 2015

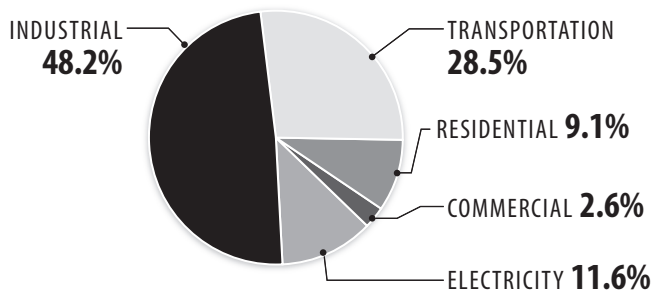

Data: Energy Information Administration

## U.S. Consumption of Biofuels, 2016

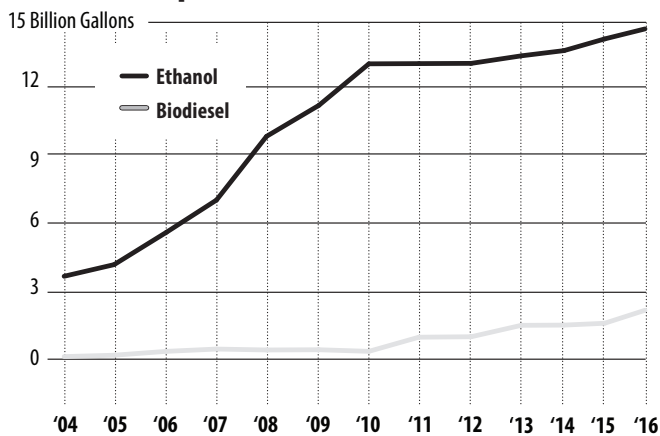

Data: Energy Information Administration





# Coal

## What Is Coal?

**Coal** is a **fossil fuel** formed from the remains of plants that lived and died hundreds of millions of years ago, when parts of the Earth were covered with huge swampy forests. Coal is called a **nonrenewable** energy source because it takes millions of years to form.

The energy we get from coal today came from the energy that plants absorbed from the sun hundreds of millions of years ago. All living plants store energy from the sun. After the plants die, this energy is usually released as the plants decay. Under certain conditions, however, the decay is interrupted, preventing the release of the stored solar energy.

100—400 million years ago, plants that fell to the bottom of the swamp began to decay as layers of dirt and water were piled on top. Heat and pressure from these layers caused a chemical change to occur, eventually creating coal over time, a **sedimentary** rock.

## History of Coal in America

Native Americans used coal long before the first settlers arrived in the New World. Hopi Indians used coal to bake the pottery they made from clay.

European settlers discovered coal in North America during the first half of the 1600s. They used very little coal at first. Instead, they relied on water wheels and burning wood to power colonial industries.

Coal became a powerhouse by the 1800s. People used coal to manufacture goods and to power steamships and railroad engines. By the time of the American Civil War, people also used coal to make iron and steel. And by the end of the 1800s, people began using coal to make electricity.

Today, coal provides 16.0 percent of America's energy needs. Around 33 percent of our electricity comes from coal-fired **power plants**.

## Coal Mining

Coal companies use two methods to mine coal: surface mining and underground mining.

**Surface mining** is used to extract about one-third of the coal in the United States. Surface mining can be used when the coal is buried less than 200 feet underground. In surface mining, the topsoil and layers of rock are removed to expose large deposits of coal. The coal is then removed by huge machines. Once the mining is finished, the

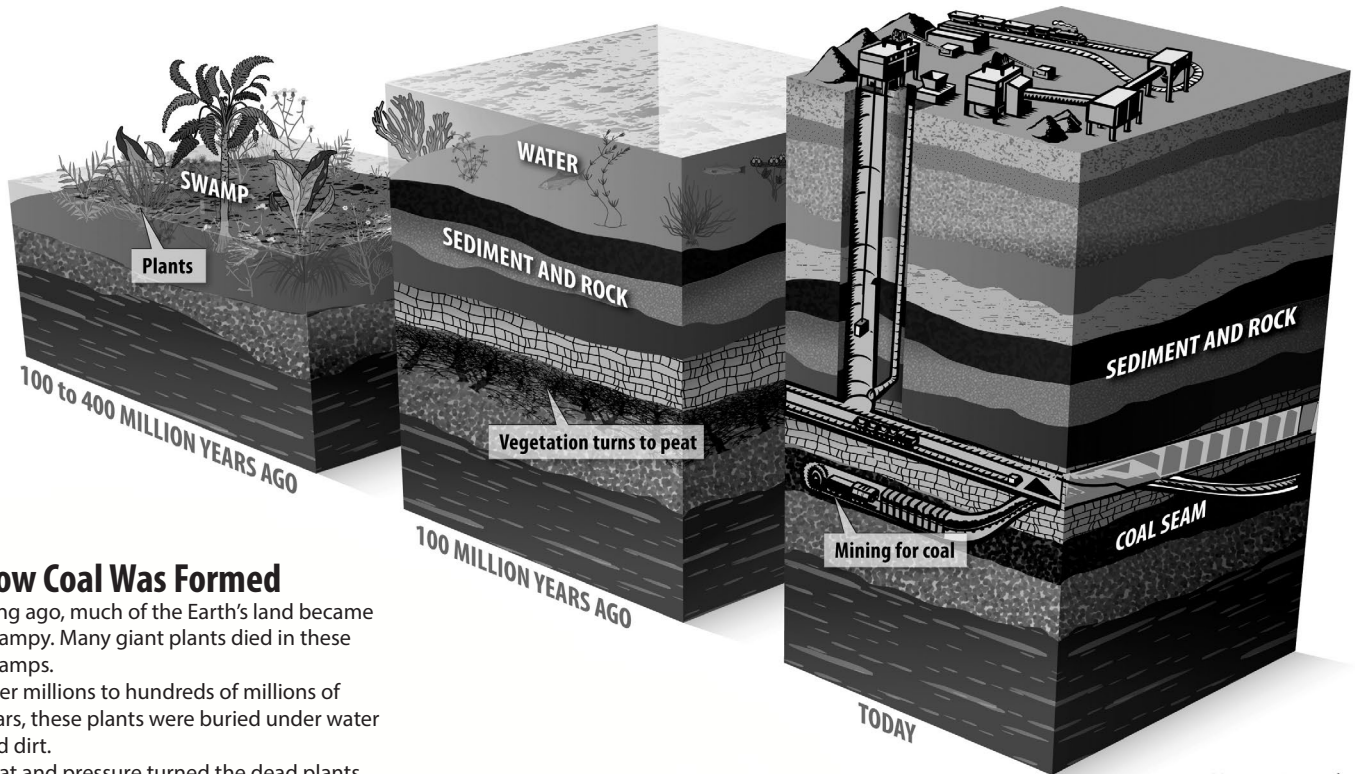

## How Coal Was Formed

Long ago, much of the Earth's land became swampy. Many giant plants died in these swamps. Over millions to hundreds of millions of years, these plants were buried under water and dirt. Heat and pressure turned the dead plants into coal.

mined area is **reclaimed**. The dirt and rock are returned to the pit, the topsoil is replaced, and the area is seeded. The land can then be used for croplands, wildlife habitats, recreation, or offices and stores.

**Underground (or deep) mining** is used when the coal is buried deep within the Earth. Some underground mines are 1,000 feet deep! To remove coal from underground mines, miners are transported down mine shafts to run machines that dig out the coal.

## Processing and Transporting Coal

After coal comes out of the ground, it goes to a preparation plant for cleaning. The plant removes rock, ash, sulfur, and other impurities from the coal. Cleaning improves the heating value of coal.

After cleaning, the coal is ready to be shipped to market. Trains are used to transport most coal. Sometimes, river barges and trucks are used to ship coal. For short distances, coal can also be moved using conveyors. Deciding how to ship coal is very important because it can cost more to ship it than to mine it.

## Coal Reserves and Production

Coal **reserves** are beds of coal still in the ground that can be mined. The United States has the world's largest known coal reserves. Depending on consumption rates, the U.S. has enough coal to last over 250 years.

Coal production is the amount of coal that is mined and sent to market. Coal is mined in 25 states. Wyoming mines the most, followed by West Virginia, Kentucky, Illinois, and Pennsylvania.

## How Coal Is Used

Roughly 91 percent of the coal mined in the U.S. today is used to make electricity. The steel and iron industries use coal for **smelting** metals. Other industries use coal, too. Paper, brick, limestone, and cement industries all use coal to make products. Very little coal is used for heating homes and buildings.

## Coal and the Environment

Burning coal produces emissions that can pollute the air. It also produces **carbon dioxide**, a **greenhouse gas**. When coal is burned, a chemical called sulfur may also be released. Sulfur mixes with oxygen to form sulfur dioxide, a chemical that can affect trees and water when it combines with moisture to produce **acid rain**.

Coal companies look for low-sulfur coal to mine. They work hard to remove sulfur and other impurities from the coal. Power plants install machines called **scrubbers** to remove most of the sulfur from coal smoke so it doesn't get into the air. Other by-products, like the ash that is left after coal is burned, once were sent to landfills. Now they are being used to build roads, make cement, and make ocean reefs for animal habitats.

### Surface Mining

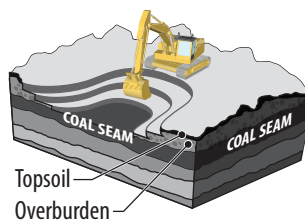

### Deep Mining

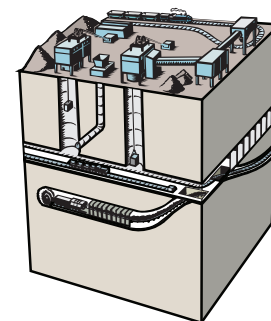

### Top Coal Producing States, 2015

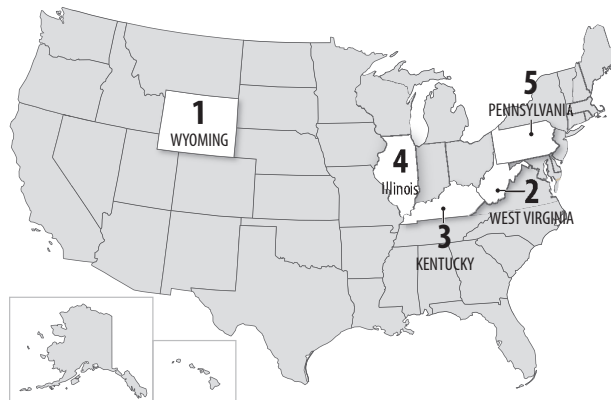

Data: Energy Information Administration

### U.S. Coal Consumption by Sector, 2015

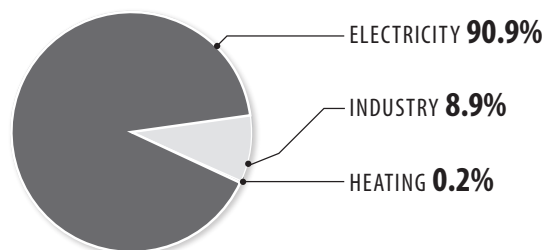

Data: Energy Information Administration

### COAL MINERS



Photo courtesy of gettyimages  
www.NEED.org



# Geothermal

## What Is Geothermal Energy?

The word **geothermal** comes from the Greek words *geo* (earth) and *therme* (heat). Geothermal energy is heat from within the Earth.

Geothermal energy is generated in the Earth's **core**, almost 4,000 miles (6,400 km) beneath the Earth's surface. The double-layered core is made up of very hot **magma** surrounding a solid iron center. Very high temperatures are continuously produced inside the Earth because of the immense pressure on the core and mantle. Rocks in the crust are warmed by the continuous, slow **radioactive decay** of rock particles, which is natural in all rocks.

Surrounding the outer core is the **mantle**, which is about 1,800 miles (2,900 km) thick and made of magma and rock. The outermost layer of the Earth, the land that forms the continents and ocean floors, is called the **crust**. The crust is three to five miles (5-8 km) thick under the oceans and 15 to 35 miles (24-56 km) thick on the continents.

The crust is not a solid piece, like the shell of an egg, but is broken into pieces called **plates**. Magma comes close to the Earth's surface near the edges of these plates. This is where volcanoes occur. The lava that erupts from volcanoes is magma that has reached the Earth's surface. Deep underground, the rocks and water in the crust absorb the heat from this magma.

We can dig wells and pump the heated, underground water to the surface. People around the world use geothermal energy to heat their homes and to produce electricity.

Geothermal energy is called a **renewable** energy source because the water is replenished by rainfall and the heat is continuously produced deep within the Earth. We won't run out of geothermal energy.

### The Earth's Interior

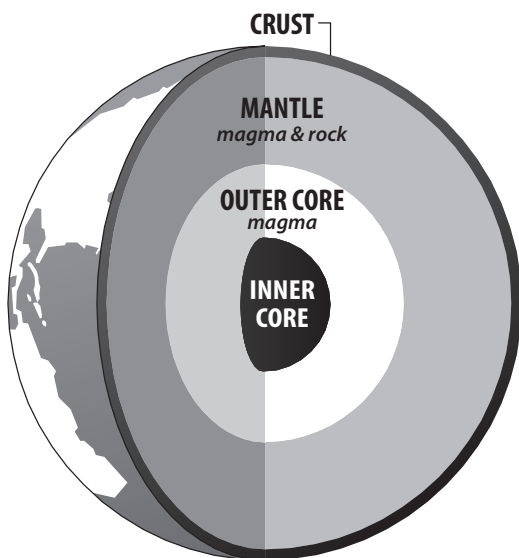

## History of Geothermal Energy

Geothermal energy was used by ancient people for heating and bathing. Even today, hot springs are used worldwide for bathing, and many people believe hot mineral waters have natural healing powers.

Using geothermal energy to produce electricity is a new industry. A group of Italians first used it in 1904. The Italians used the natural steam erupting from the Earth to power a turbine generator.

The first successful American geothermal plant began operating in 1960 at The Geysers in northern California. There are now geothermal power plants in seven states, with many more in development. Most of these geothermal power plants are in California with the remainder in Nevada, Utah, Hawaii, Oregon, Idaho, New Mexico, and Montana.

## Finding Geothermal Energy

What are the characteristics of geothermal resources? Some visible features of geothermal energy are volcanoes, hot springs, geysers, and fumaroles. But you cannot see most geothermal resources. They are deep underground. There may be no clues above ground that a geothermal reservoir is present below.

Geologists use different methods to find geothermal reservoirs. The only way to be sure there is a reservoir is to drill a well and test the temperature deep underground.

The most active geothermal resources are usually found along major plate boundaries where earthquakes and volcanoes are concentrated. Most of the geothermal activity in the world occurs in an area called the **Ring of Fire**. This area borders the Pacific Ocean.

## Hydrothermal Resources

There is more than one type of geothermal energy, but only one kind is widely used to make electricity. It is called **hydrothermal** energy. Hydrothermal resources have two common ingredients: water (*hydro*) and heat (*thermal*). Depending on the temperature of the hydrothermal resource, the heat energy can either be used for making electricity or for heating.

### ■ Low Temperature Resources: Heating

Hydrothermal resources at low temperatures (50-300°F, 10-150°C) are located everywhere in the United States, just a few feet below the ground. This low temperature geothermal energy is used for heating homes and buildings, growing crops, and drying lumber, fruits, and vegetables.

In the U.S., geothermal heat pumps are used to heat and cool homes and public buildings. In fact, each year about 50,000 **geoexchange systems** are installed in the U.S. Almost 90 percent of the homes and businesses in Iceland use geothermal energy for space heating.



## Geothermal Power Plant

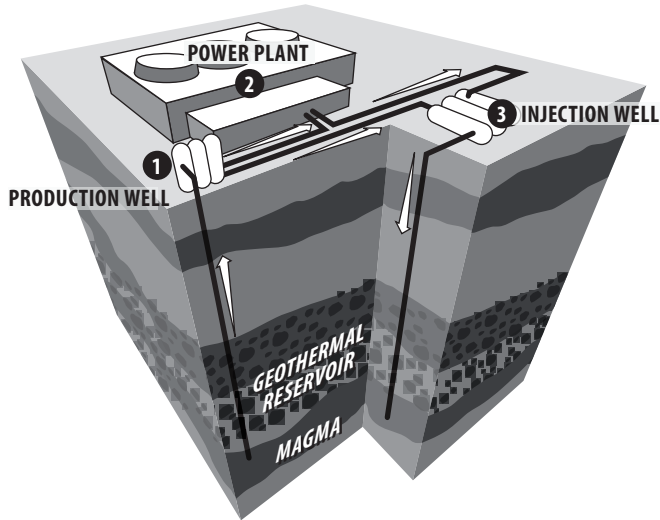

1. **Production Well:** Geothermal fluids, such as hot water and steam, are brought to the surface and piped into the power plant.
2. **Power Plant:** Inside the power plant, the geothermal fluid turns the turbine blades, which spins a shaft, which spins magnets inside a large coil of wire to generate electricity.
3. **Injection Well:** Used geothermal fluids are returned to the reservoir.

### High Temperature Resources: Electricity

Hydrothermal resources at high temperatures (250-700°F, 150-370°C) can be used to make electricity.

These high-temperature resources may come from either dry steam **wells** or hot water wells. We can use these resources by drilling wells into the Earth and piping the steam or hot water to the surface. Geothermal wells are one to two miles deep.

In a **dry steam plant**, the steam from the geothermal reservoir is piped directly from a well to a turbine generator to make electricity. In a hot water plant, some of the hot water is turned into steam. The steam powers a turbine generator just like a dry steam plant. When the steam cools, it condenses to water and is injected back into the ground to be used over and over again.

Geothermal energy produces only a small percentage of U.S. electricity. Today, it produces almost 17 billion kilowatt-hours, or less than one percent of the electricity produced in this country.

## Geothermal Energy and the Environment

Geothermal energy does little damage to the environment. Another advantage is that geothermal plants don't have to transport fuel, like most power plants. Geothermal plants sit on top of their fuel source. Geothermal power plants have been built in deserts, in the middle of crops, and in mountain forests.

Geothermal plants produce almost no emissions because they do not burn fuel to generate electricity.

## Residential Geexchange Units

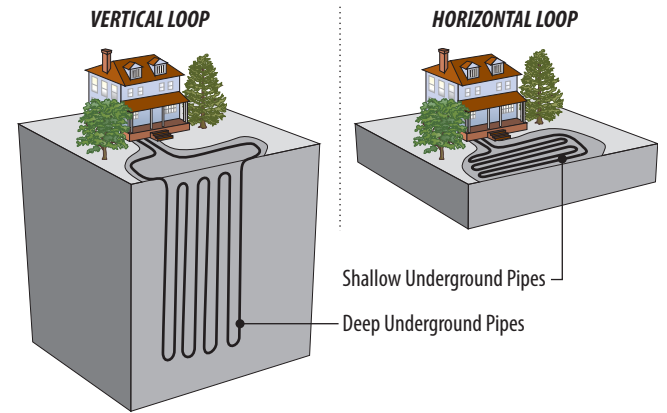

## Ring of Fire

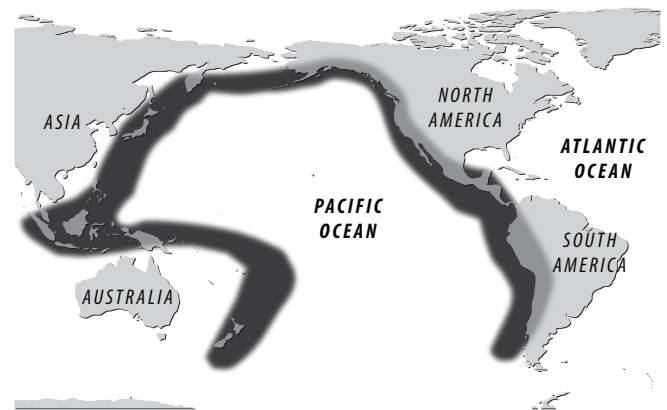

Most of the geothermal activity in the world occurs around the Pacific Ocean in an area called the Ring of Fire.

## Top Geothermal Producing States, 2015

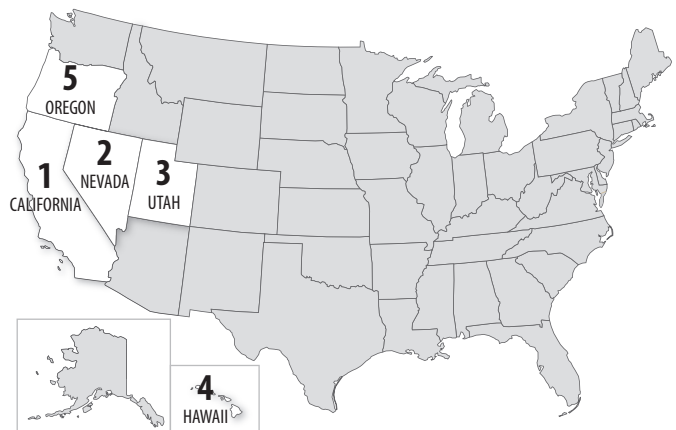

Data: Energy Information Administration



# Hydropower

## What Is Hydropower?

**Hydropower** (the prefix *hydro* means water) is energy that comes from the force of moving water.

The movement of water between the Earth and the atmosphere is part of a continuous cycle called the water cycle. The sun draws moisture up from the oceans and rivers, and this moisture condenses into clouds. The moisture is released from the clouds as rain or snow. The oceans and rivers are replenished with moisture, and the cycle starts again.

Gravity causes the water on the Earth to move from places of high ground to places of low ground. The force of moving water can be very powerful.

Hydropower is called a **renewable** energy source because it is replenished by snow and rainfall. As long as the sun shines and the rain falls, we won't run out of this energy source.

## History of Hydropower

Water has been used as a source of energy for centuries. The Greeks used water wheels to grind wheat into flour more than 2,000 years ago. In the early 1800s, American and European factories used water wheels to power machines.

The water wheel is a simple machine. The wheel picks up water in buckets located around the wheel. The weight of the water causes the wheel to turn. Water wheels convert the energy of the moving water into useful energy to grind grain, drive sawmills, or pump water.

In the late 19th century, hydropower was first used on the Fox River in Appleton, WI to generate electricity. The first **hydroelectric power plant** was built in 1882. In the years that followed, many more hydropower dams were built. By the 1940s, most of the best sites in the United States for large dams had been developed.

At about the same time, fossil fuel power plants began to be popular. These plants could make electricity more cheaply than hydropower plants. It wasn't until the price of oil skyrocketed in the 1970s that people became interested in hydropower again.

## Hydropower Dams

It is easier to build a hydropower plant on a river where there is a natural waterfall, which is why a hydropower plant was built at Niagara Falls. Building **dams** across rivers to produce artificial waterfalls is the next best way.

Dams are built on rivers where the terrain of the land produces a lake or **reservoir** behind it. Today there are about 87,000 dams in the United States, but only 2,200 were built specifically to generate electricity.

Most of the dams in the United States were built to control flooding, to irrigate farm land, or for recreation, not for electricity production. We could increase the amount of hydropower produced in this country by putting equipment to generate electricity on many of the existing dams.

## Hydropower Plants

Hydropower plants use modern turbine **generators** to produce electricity just as coal, oil, or nuclear power plants do. The difference is in the source used to spin the turbine.

A typical hydropower plant is a system that has three main parts: a reservoir where water can be stored, a dam with gates to control water flow, and a power plant where the electricity is produced.

A hydropower plant uses the force of flowing water to produce electricity. A dam opens gates at the top to allow water from the

### The Water Cycle

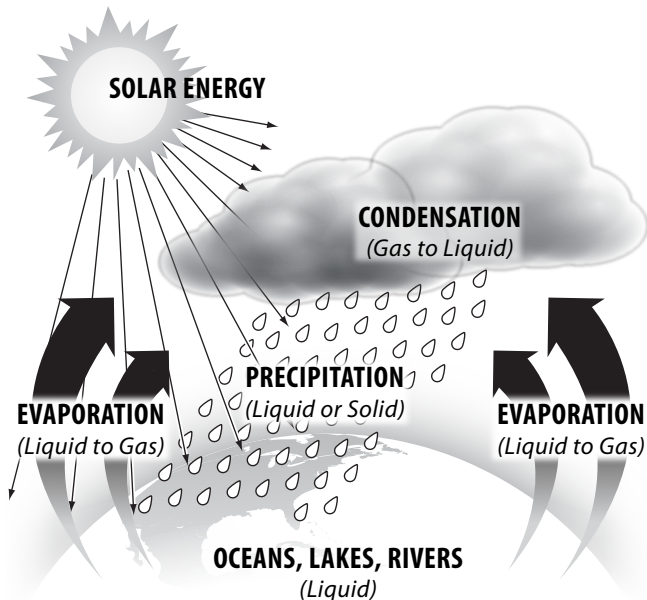



reservoir to flow down large tubes called **penstocks**. At the bottom of the penstocks, the fast-moving water spins the blades of the turbines. The turbines are attached to generators to produce electricity, which is transported along transmission lines to a utility company.

## Storing Energy

One of the biggest advantages of hydropower dams is their ability to store energy. After all, the water in the reservoir has **gravitational potential energy**. Water can be stored in a reservoir and released when electricity is needed. During the night, when consumers use less electricity, the gates can be closed and water held in the reservoir. Then, during the day, when consumers need more electricity, the gates can be opened so that the water can flow through the plant to generate electricity.

## Amount and Cost of Hydropower

Depending upon the amount of rainfall during the year, hydropower can provide anywhere between five and ten percent of the country's electricity. In 2015, hydropower provided about 6.0 percent of the nation's electricity. Globally, hydropower is a significant energy source, producing 17 percent of the world's electricity. In South America, a little more than half of the electricity is produced by hydropower.

Hydropower is the cheapest way to generate electricity in the United States today. Hydropower is cheaper than electricity from coal or nuclear plants for many reasons. The fuel—flowing water—does not have to be transported, and is free to use, unlike coal and uranium.

## Hydropower and the Environment

Hydropower is a clean energy source. A hydropower plant produces no air pollution because it does not burn fuel, but it does affect the environment in other ways.

When dams are built, water patterns and the amount of flow in rivers are altered. Some wildlife and natural resources are also affected. Many dams today have **spillway gates** to control the flow of excess water, and incorporate **fish ladders**, elevators, and other devices to help fish swim up the river.

On the positive side, hydropower's fuel supply (flowing water) is clean and renewable—replenished by the water cycle. There are also other benefits. Dams can be designed to control flood water, and reservoirs provide lakes for boating, swimming, fishing, and other recreational activities.

### Hydropower Plant

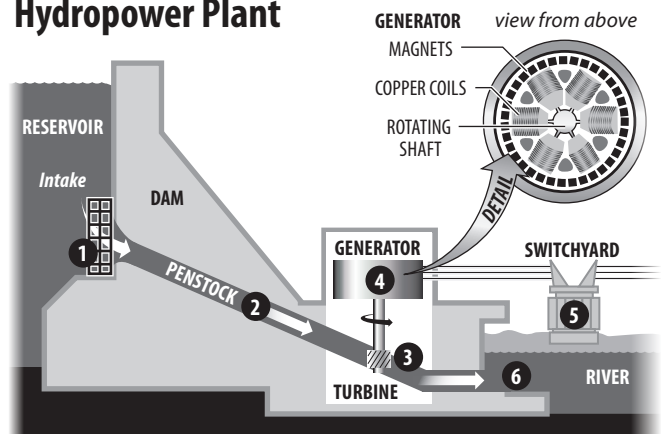

1. Water in a reservoir behind a hydropower dam flows through an intake screen, which filters out large debris, but allows fish to pass through.
2. The water travels through a large pipe, called a penstock.
3. The force of the water spins a turbine at a low speed, allowing fish to pass through unharmed.
4. Inside the generator, the shaft spins coils of copper wire inside a ring of magnets. This creates an electric field, producing electricity.
5. Electricity is sent to a switchyard, where a transformer increases the voltage, allowing it to travel through the electric grid.
6. Water flows out of the penstock into the downstream river.

### Top Hydropower Producing States, 2015

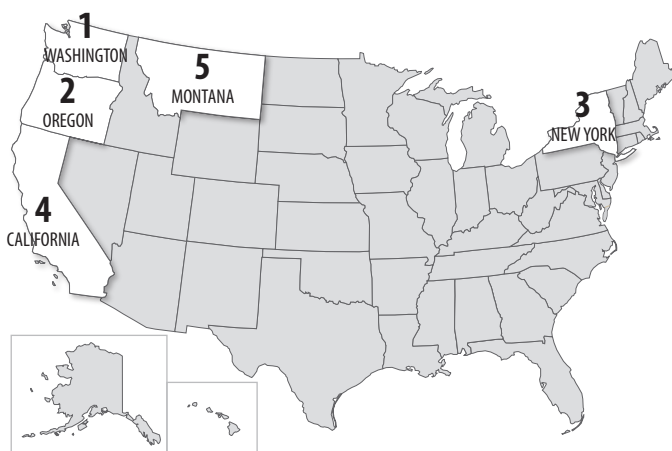

Data: Energy Information Administration



# Natural Gas

## What Is Natural Gas?

**Natural gas** is a **fossil fuel** like petroleum and coal. Natural gas is called a fossil fuel because it was formed from the remains of ancient sea plants and animals. When the plants and tiny sea animals died hundreds of millions of years ago, they sank to the bottom of the oceans where they were buried by sediment and sand. This eventually turned into **sedimentary** rock. The layers of plant and animal matter and sedimentary rock continued to build until the pressure and heat from the Earth turned the remains into petroleum and natural gas.

Natural gas is trapped in underground rocks much like a sponge traps water in pockets. Natural gas is really a mixture of gases. The main ingredient is **methane**. Methane has no color, odor, or taste. As a safety measure, natural gas companies add an odorant, **mercaptan**, to the gas so that leaking gas can be detected (it smells like rotten eggs). People use natural gas mostly for heating. Natural gas should not be confused with gasoline, which is made from petroleum.

Natural gas is almost always considered **nonrenewable**, which means we cannot make more in a short time. However, there are some renewable sources of methane, such as landfills.

## History of Natural Gas

The ancient people of Greece, Persia, and India discovered natural gas many centuries ago. The people were mystified by the burning springs created when natural gas seeped from cracks in the ground and was ignited by lightning. They sometimes built temples around these eternal flames and worshipped the fire.

About 2,500 years ago, the Chinese recognized that natural gas could be put to work. The Chinese piped the gas from shallow wells and burned it under large pans to evaporate sea water to make salt.

In 1816, natural gas was first used in America to fuel street lamps in Baltimore, Maryland. Soon after, in 1821, William Hart dug the United States' first successful natural gas well in Fredonia, New York. It was just 27 feet deep, quite shallow compared to today's wells. Today, natural gas is the country's second largest supplier of energy, after petroleum.

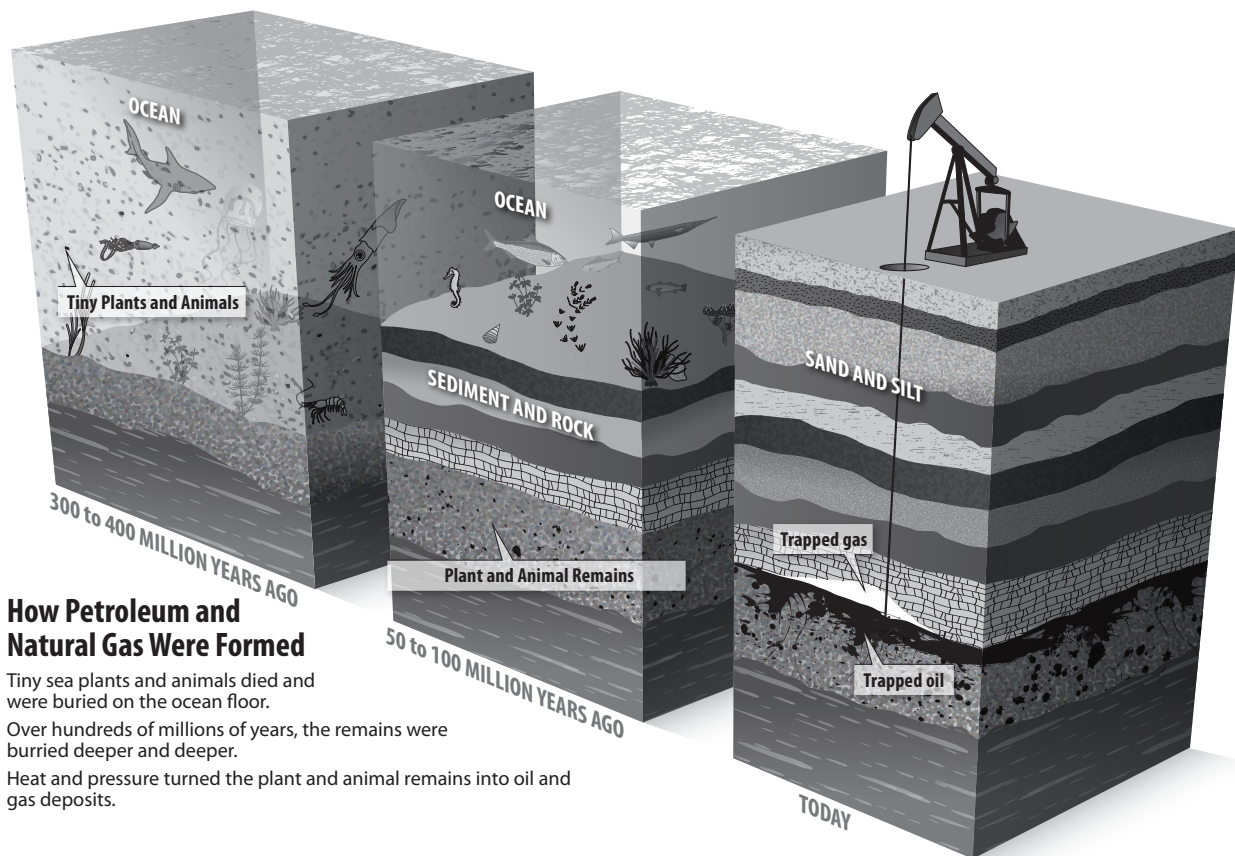

### How Petroleum and Natural Gas Were Formed

Tiny sea plants and animals died and were buried on the ocean floor.

Over hundreds of millions of years, the remains were buried deeper and deeper.

Heat and pressure turned the plant and animal remains into oil and gas deposits.

Note: not to scale

## Producing Natural Gas

Natural gas can be hard to find since it is often trapped in **porous** rocks deep underground. Scientists use many methods to find natural gas deposits. They may look at surface rocks to find clues about underground formations. They may set off small explosions or drop heavy weights on the surface to record the sound waves as they bounce back from the rock layers underground.

Natural gas can be found in pockets by itself or in petroleum deposits. Natural gas wells average more than 8,600 feet (2.5 km) deep!

After natural gas comes out of the ground, it is sent to a plant where it is cleaned of impurities and separated into its various parts. Natural gas is mostly methane, but it also contains small amounts of other gases such as propane and butane.

Today natural gas is produced in 34 states, though just five states produce almost two-thirds of our supply. Natural gas is also produced **offshore**. A little more than 5 percent of natural gas production came from offshore wells in 2015. Scientists estimate that we have enough natural gas to last 93 years at current prices and rate of consumption.

Natural gas can also come from other sources, such as the methane gas found in coal. **Coal bed methane** was once considered just a safety hazard to miners, but now it is a valuable source of energy. Another source of natural gas is the gas produced in landfills. Landfill gas, a **biogas**, is considered a renewable source of natural gas since it comes from something continually produced—trash.

## Shipping Natural Gas

Natural gas is usually shipped by **pipeline**. About two million miles of pipelines connect gas fields to cities, to homes, and to businesses. Natural gas is sometimes transported thousands of miles in these pipelines to its final destination. It can take five days to move natural gas from Texas to New York.

Eventually, the gas reaches the city gate of a local gas utility. Smaller pipes carry the gas the last few miles to homes and businesses. A gas meter measures the volume of gas a consumer uses.

## Who Uses Natural Gas?

Just about everyone in the United States uses natural gas. Natural gas is used for 29.0 percent of U.S. energy. Industry burns natural gas for heat to manufacture goods. Natural gas is also used as an ingredient in fertilizer, glue, paint, laundry detergent, and many other items.

Residences, or homes, use natural gas for heating. Like residences, commercial buildings use natural gas mostly for heating. Commercial users include stores, offices, schools, churches, and hospitals.

Natural gas can also be used to generate electricity. It accounts for over 32 percent of U.S. electricity generated. Many new power plants are using natural gas as fuel because it is cleaner burning and can produce electricity quickly when it is needed for periods of high demand.

A small amount of natural gas is also used as fuel for automobiles. Natural gas is cleaner burning than gasoline, but to use it, vehicles must have special equipment.

## Top Natural Gas Producing States, 2015



Data: Energy Information Administration

## U.S. Natural Gas Consumption by Sector, 2015

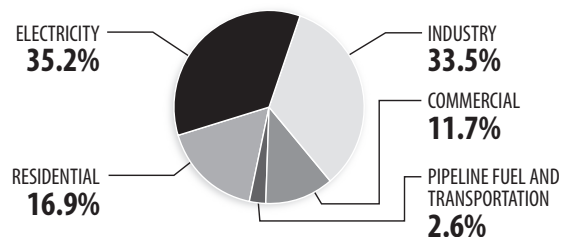

Data: Energy Information Administration

## Locations of Natural Gas

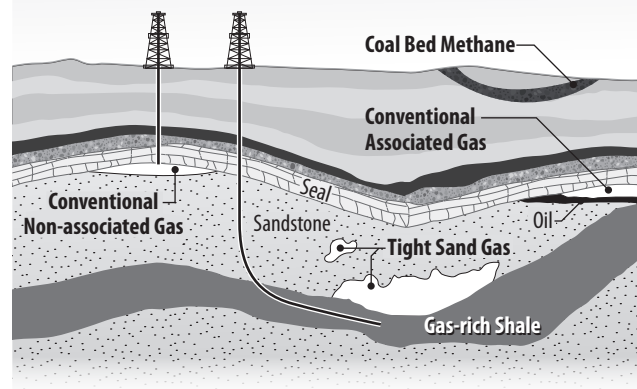

## Natural Gas and the Environment

Burning biomass or any fossil fuel, including natural gas, releases emissions into the air, including **carbon dioxide**, a **greenhouse gas**.

Natural gas and propane are the cleanest burning fossil fuels. Compared to coal and petroleum, natural gas releases much less sulfur, carbon dioxide, and ash when it is burned. Scientists are looking for new sources of natural gas and new ways to use it.





# Petroleum

## What Is Petroleum?

**Petroleum** is a **fossil fuel**. Petroleum is often called **crude oil**, or **oil**. It is called a fossil fuel because it was formed from the remains of tiny sea plants and animals that died hundreds of millions of years ago. When the plants and animals died, they sank to the bottom of the oceans.

Here, they were buried by thousands of feet of sand and sediment, which turned into **sedimentary rock**. As the layers increased, they pressed harder and harder on the decayed remains at the bottom. The pressure and some heat changed the remains and, eventually, petroleum was formed.

Petroleum deposits are locked in **porous** rocks almost like water is trapped in a wet sponge. When crude oil comes out of the ground, it can be as thin as water or as thick as tar. Petroleum is called a **nonrenewable** energy source because it takes hundreds of millions of years to form. We cannot make new petroleum reserves.

## History of Oil

People have used petroleum since ancient times. The ancient Chinese and Egyptians burned oil to light their homes. Before the 1850s, Americans used whale oil to light their homes. When whale oil became scarce due to overfishing, people skimmed the oil that

seeped to the surface of ponds and streams. The demand for oil grew and, in 1859, Edwin Drake drilled the first oil well near Titusville, Pennsylvania.

At first, the crude oil was refined or made into kerosene for lighting. Gasoline and other products made during refining were thrown away because people had no use for them. This all changed when Henry Ford began mass producing automobiles in 1913. Everyone wanted an automobile and they all ran on gasoline. Gasoline was the fuel of choice because it provided the greatest amount of energy in relation to cost and ease of use.

Today, Americans use more petroleum than any other energy source, mostly for transportation. Petroleum provides 36.6 percent of the energy we use.

## Producing Oil

Geologists look at the types of rocks and the way they are arranged deep within the Earth to determine whether oil is likely to be found at a specific location. Even with new technology, oil exploration is expensive and often unsuccessful. Only about 60 percent of **exploratory wells** produce oil. When scientists think there may be oil in a certain place, a petroleum company brings in a **drilling rig** and raises an oil **derrick** that houses the tools and pipes they need to drill a well. The typical oil well is over one mile deep. If oil is found, a pump moves the oil through a pipe to the surface.

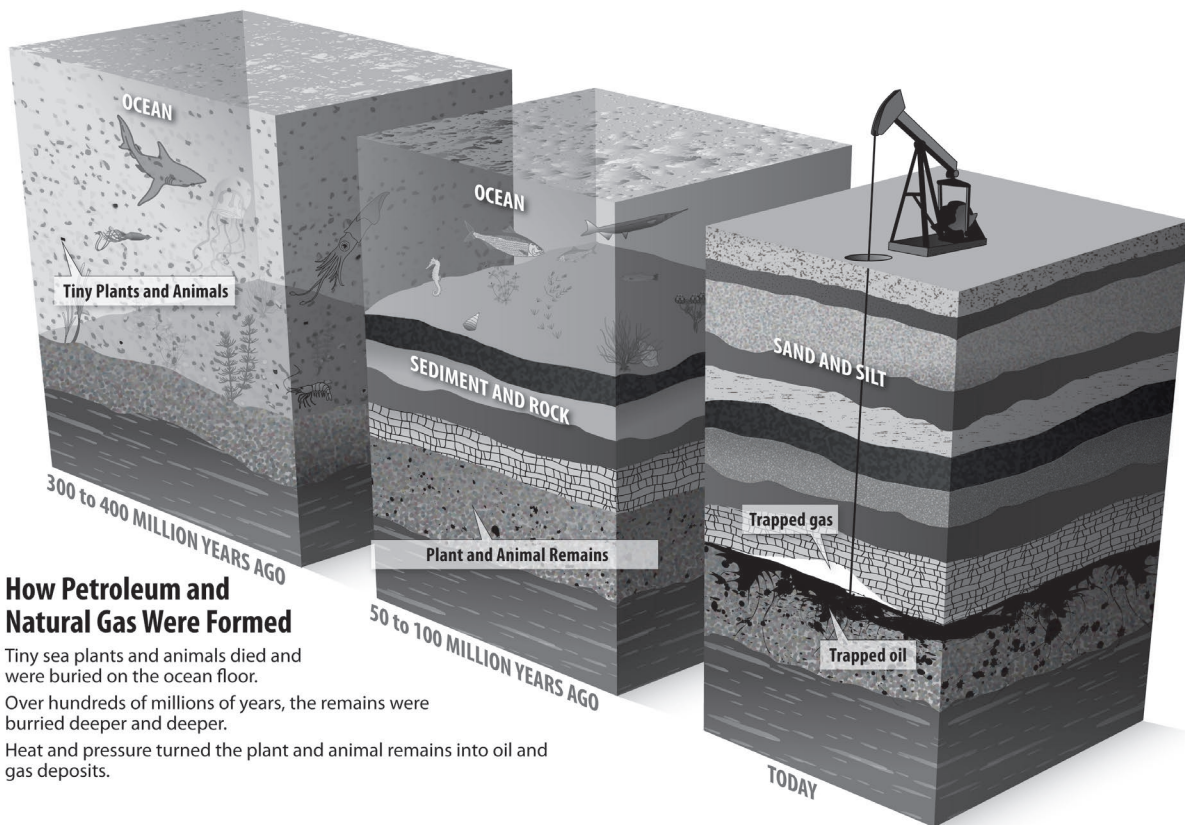

### How Petroleum and Natural Gas Were Formed

Tiny sea plants and animals died and were buried on the ocean floor.

Over hundreds of millions of years, the remains were buried deeper and deeper.

Heat and pressure turned the plant and animal remains into oil and gas deposits.

Note: not to scale

## Top Petroleum Producing States, 2015

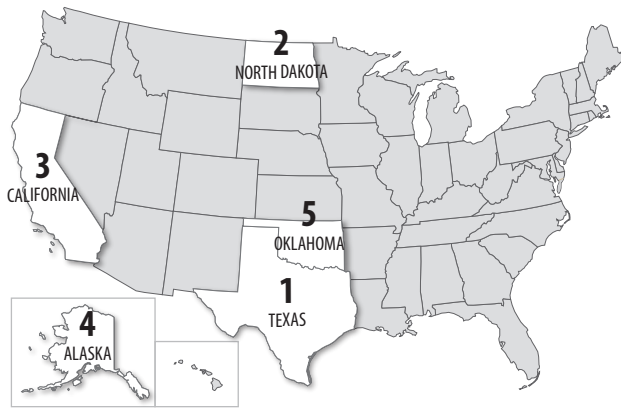

Data: Energy Information Administration

About one-sixth of the oil the U.S. produces comes from **offshore** wells. Some wells are a mile under the ocean. Some of the rigs used to drill these wells float on top of the water. It takes a lot of money and technology to drill and find oil in the ocean.

Texas produces more oil than any other state, followed by North Dakota, California, Alaska, and Oklahoma. Americans use much more oil than we produce. Today, the U.S. imports about 48 percent of the oil it consumes from other countries.

## From Well to Market

We can't use crude oil as it comes out of the ground. We must change it into fuels that we can use. The first stop for crude oil is at a petroleum **refinery**. A refinery is a factory that processes oil.

The refinery cleans and separates the crude oil into many fuels and products. The most important one is gasoline. Other petroleum products are diesel fuel, heating oil, and jet fuel. Industry uses petroleum as a **feedstock** to make plastics and many other products.

## Shipping Petroleum

After the refinery, most petroleum products are shipped out through **pipelines**. There are about 95,000 miles (153,000 km) of underground pipelines in the United States transporting refined petroleum products. Pipelines are the safest and cheapest way to move big shipments of petroleum. It can take 15 days to move a shipment of gasoline from Houston, Texas, to New York City. Petroleum can also be moved over water in a tanker.

Special companies called **jobbers** buy petroleum products from oil companies and sell them to gasoline stations and to other big users such as industries, power companies, and farmers.

## Oil and the Environment

Petroleum products—gasoline, medicines, fertilizers, and others—have helped people all over the world, but there is a trade-off. Petroleum production, exploration, and the use of petroleum products cause air and water pollution.

Drilling for and transporting oil can endanger wildlife and the environment if it spills into rivers or oceans. Leaking underground storage tanks can pollute groundwater and create noxious fumes. Processing oil at the refinery can contribute to air and water pollution. Burning gasoline to fuel our cars contributes to air

## Products Produced From a Barrel of Oil, 2015

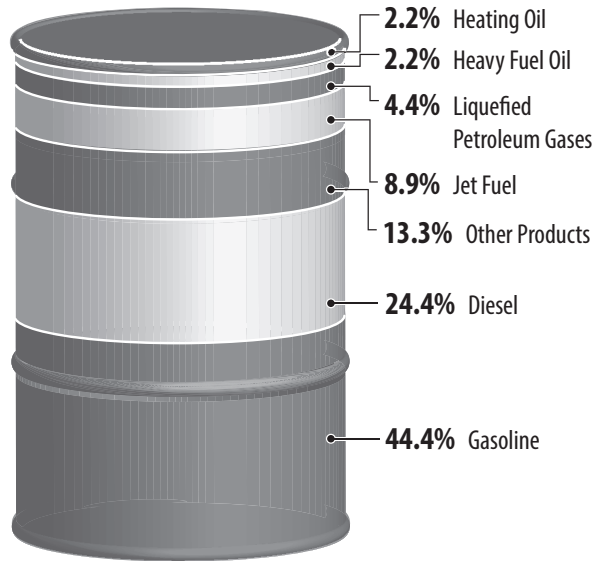

Data: Energy Information Administration

## Other Petroleum Products

Ink	Enamel	Pantyhose	Fishing rods
Hand lotion	Movie film	Artificial limbs	Dice
Nail polish	Balloons	Antihistamines	Fertilizers
Heart valves	Antiseptics	Oil filters	Electrical tape
Toothbrushes	Aspirin	Ballpoint pens	Trash bags
Dashboards	Paint brushes	Skis	Insecticides
Crayons	Purses	Pajamas	Floor wax
Toothpaste	Sunglasses	Golf balls	Shampoo
Luggage	Football	Perfumes	Cold cream
Parachutes	Deodorant	Cassettes	Tires
Guitar strings	Glue	Contact lenses	Cameras
DVDs	Dyes	Shoe polish	Detergents

## U.S. Petroleum Consumption by Sector, 2015

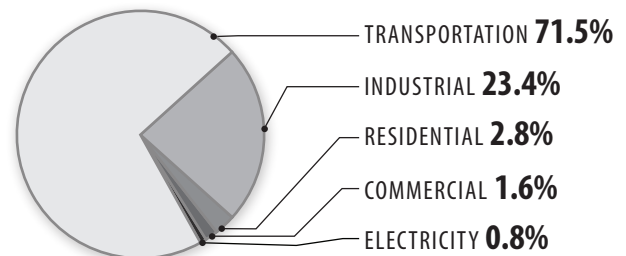

Data: Energy Information Administration

\*Total does not equal 100% due to independent rounding.

pollution. Even the careless disposal of waste oil drained from the family car can pollute rivers and lakes.

The petroleum industry works hard to protect the environment. Gasoline and diesel fuel have been changed to burn cleaner. And oil companies work to make sure that they drill and transport oil as safely as possible.





# Propane

## What Is Propane?

**Propane** is an energy-rich gas that is included in raw petroleum and natural gas. Propane is found mixed with deposits of natural gas and petroleum underground. Propane is called a **fossil fuel** because it was formed hundreds of millions of years ago from the remains of tiny sea animals and plants.

When the plants and animals died, they sank to the bottom of the oceans where they were buried by layers of sediment and sand that turned into **sedimentary** rock. Over time, the layers became thousands of feet thick. The layers were subjected to enormous heat and pressure, changing the remains into petroleum and natural gas deposits. Pockets of these fossil fuels became trapped in rocks like a sponge holds water.

Propane is one of the many fuels that are included in the **liquefied petroleum gas** (or **LPG**) family. In the United States, propane and LPG often mean the same thing, because propane is the most common type of LPG used. Just as water can be a liquid or a gas (steam), so can propane. Under normal conditions, propane is a gas. Under pressure, propane becomes a liquid.

Propane is stored as a liquid fuel in pressurized tanks because it takes up much less space in that form. Gaseous propane takes up 270 times more space than liquid propane. A thousand gallon tank holding gaseous propane would provide a family enough cooking fuel for one week. The same tank holding liquid propane would provide enough cooking fuel for over five years! Propane becomes a gas when it is released to fuel gas appliances.

Propane is very similar to natural gas. Like natural gas, propane is colorless and odorless. An odorant, called **mercaptan**, is added to propane so escaping gas can be detected. And like all fossil fuels—coal, petroleum, natural gas—propane is a **nonrenewable** energy source. That means we cannot renew our propane supplies in a short time.

### Liquefied Propane

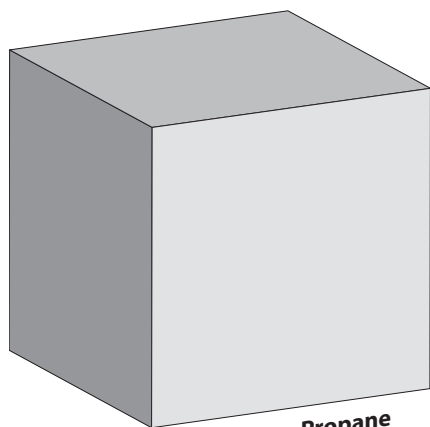

**Gaseous Propane**  
Volume = 270 gallons

As a gas, propane occupies 270 times more space than when it is pressurized into a liquid.

**Liquid Propane**  
Volume = 1 gallon

## History of Propane

Propane has been around for millions of years, but it wasn't discovered until 1912. Scientists were trying to find a better way to store gasoline, which had a tendency to evaporate when it was stored.

An American scientist, Dr. Walter Snelling, discovered that propane gas could be changed into a liquid and stored at moderate pressure. Just one year later, the commercial propane industry began heating American homes with propane.

## Producing Propane

Propane comes from natural gas and petroleum wells. A little more than half of the propane used in the United States comes from raw natural gas. Raw natural gas is about 90 percent **methane**, five percent propane, and five percent other gases. The propane is separated from the other gases at a natural gas processing plant.

The remainder of our propane supply comes from petroleum refineries or is imported. Many gases are separated from petroleum at refineries. Since the U.S. imports 48 percent of the petroleum we use, much of the propane is separated from this imported oil.

## Transporting Propane

How does propane get to consumers? It is usually moved through **pipelines** to **distribution terminals** across the nation. These distribution terminals are like warehouses that store goods before shipping it to stores. Sometimes in the summer, when people need less propane for heating, it is stored in large underground caverns.

From the distribution terminals, propane goes by railroad, trucks, barges, and supertankers to bulk plants. A **bulk plant** is where local propane dealers come to fill their small tank trucks. People who use very little propane—backyard barbecue cooks, for example—must take their propane tanks to dealers to be filled.

## How Propane Is Used

Propane provides the U.S. with less than two percent of its energy. Propane is used by industry, homes, farms, and businesses—mostly for heating. It is also used as a transportation fuel.

### ▪ Industry

Over seventy-eight percent of the propane we use is used by industry. Many industries find propane well-suited for special needs. Metal workers use small propane tanks to fuel cutting torches. Portable propane heaters give construction and road workers warmth in cold weather.

Propane is also used to heat asphalt for highway construction and repairs. And because propane burns so cleanly, forklift trucks powered by propane can operate safely inside factories and warehouses.

## How Propane Is Used

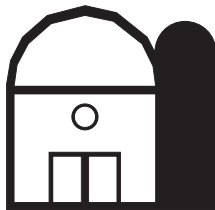

To heat barns and operate farm equipment

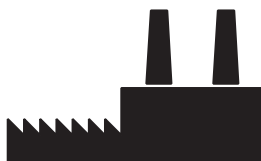

To make products and fuel industry



To fuel hot air balloons

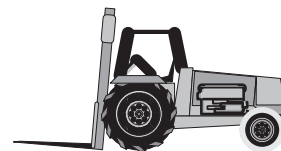

To fuel machinery that is used indoors



To fuel backyard grills



To heat homes



To fuel fleet vehicles



To fuel appliances

### ■ Homes

Propane is mostly used in rural areas that do not have access to natural gas service. Homes use propane for heating, hot water, cooking, and clothes drying. Many families have barbecue grills fueled by propane gas. Some families have recreational vehicles equipped with propane appliances.

### ■ Farms

Many of America's farms rely on propane. Farmers use propane to dry crops, power tractors, and heat greenhouses and chicken coops.

### ■ Businesses

Businesses—office buildings, laundromats, fast-food restaurants, and grocery stores—use propane for heating and cooking.

### ■ Transportation Fuel

Propane has been used as a transportation fuel for many years. Today, many taxicab companies, government agencies, and school districts use propane instead of gasoline to fuel their fleets of vehicles. Propane has several advantages over gasoline. First, propane is cleaner-burning and leaves engines free of deposits. Second, engines that use propane emit fewer pollutants into the air than engines that use gasoline.

Why isn't propane used as a transportation fuel more often? For one reason, it's not as easy to find as gasoline. Have you ever seen a propane filling station? Second, automobile engines have to be adjusted to use propane fuel, and these adjustments can be costly. Third, there is a slight drop in miles traveled per gallon when propane is used to fuel vehicles.

## U.S. Propane Consumption by Sector, 2015

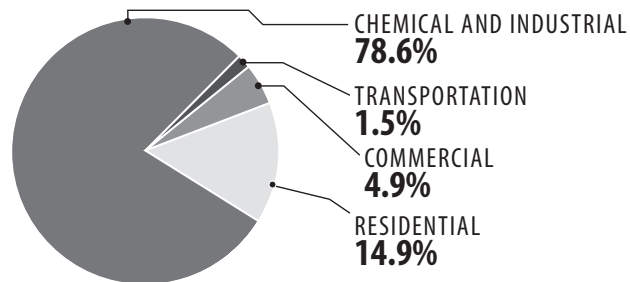

\* Total does not equal 100% due to independent rounding.  
Data: Energy Information Administration

## Propane Truck

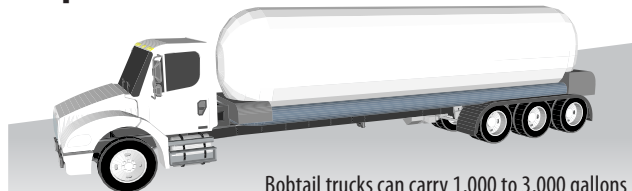

Bobtail trucks can carry 1,000 to 3,000 gallons of liquid propane to local distributors.

## Propane and the Environment

Propane is a very clean burning fossil fuel, which explains its use in indoor settings. It was approved as an alternative fuel under the Clean Air Act, as well as the National Energy Policy Act of 1992.

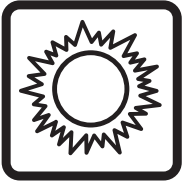

# Solar

## What Is Solar Energy?

Every day, the sun radiates (sends out) an enormous amount of energy—called **solar energy**. It radiates more energy in one day than the world uses in one year. This energy comes from within the sun itself.

Like most stars, the sun is a big gas ball made up mostly of hydrogen and helium gas. The sun makes energy in its inner core in a process called nuclear **fusion**.

It takes the sun's energy just a little over eight minutes to travel the 93 million miles to Earth. Solar energy travels at the speed of light, or 186,000 miles per second, or  $3.0 \times 10^8$  meters per second.

Only a small part of the visible **radiant energy** (light) that the sun emits into space ever reaches the Earth, but that is more than enough to supply all our energy needs. Every hour enough solar energy reaches the Earth to supply our nation's energy needs for a year! Solar energy is considered a **renewable** energy source due to this fact.

Today, people use solar energy to heat buildings and water and to generate electricity. Solar energy accounts for a very small percentage of U.S. energy—less than one percent. Solar energy is mostly used by residences and to generate electricity.

## Solar Collectors

Heating with solar energy is not as easy as you might think. Capturing sunlight and putting it to work is difficult because the solar energy that reaches the Earth is spread out over a large area. The sun does not deliver that much energy to any one place at any one time.

The amount of solar energy an area receives depends on the time of day, the season of the year, the cloudiness of the sky, and how close you are to the Earth's Equator.

A **solar collector** is one way to capture sunlight and change it into usable heat energy. A closed car on a sunny day is like a solar collector. As sunlight passes through the car's windows, it is absorbed by the seat covers, walls, and floor of the car. The absorbed light changes into heat. The car's windows let light in, but they don't let all the heat out. A closed car can get very hot!

## Solar Space Heating

**Space heating** means heating the space inside a building. Today, many homes use solar energy for space heating. A passive solar home is designed to let in as much sunlight as possible. It is like a big solar collector.

Sunlight passes through the windows and heats the walls and floor inside the house. The light can get in, but the heat is trapped inside. A **passive solar home** does not depend on mechanical equipment, such as pumps and blowers, to heat the house, whereas **active solar homes** do.

## Fusion

The process of fusion most commonly involves hydrogen isotopes combining to form a helium atom with a transformation of matter. This matter is emitted as radiant energy.

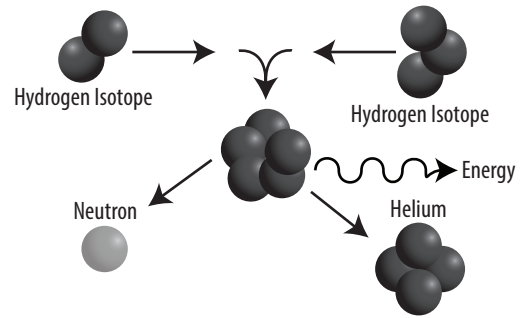

## Solar Collector

On a sunny day, a closed car becomes a solar collector. Light energy passes through the window glass, is absorbed by the car's interior, and converted into heat energy. The heat energy becomes trapped inside.

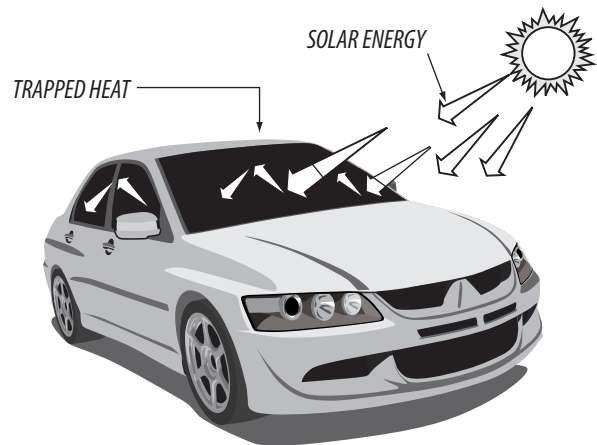

## Passive Solar Home

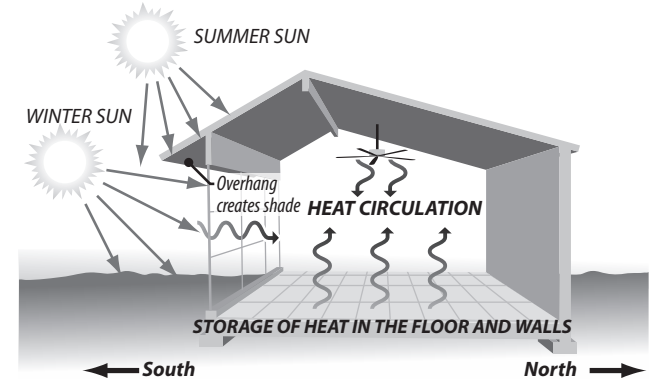



## Solar Water Heating

Solar energy can be used to heat water. Heating water for bathing, dishwashing, and clothes washing is the second largest home energy cost. Installing a solar water heater can reduce your water heating bill by as much as 50 percent.

A solar water heater works a lot like solar space heating. In our hemisphere, a solar collector is mounted on the south side of a roof where it can capture sunlight. The sunlight heats water in a tank. The hot water is piped to faucets throughout a house, just as it would be with an ordinary water heater.

## Solar Electricity

Solar energy can also be used to produce electricity. Two ways to make electricity from solar energy are photovoltaics and solar thermal systems.

### ■ Photovoltaic Electricity

**Photovoltaic** comes from the words *photo*, meaning light, and *volt*, a measurement of electricity. Sometimes photovoltaic cells are called PV cells or **solar cells** for short. You are probably familiar with photovoltaic cells. Solar-powered toys, calculators, and roadside telephone call boxes all use solar cells to convert sunlight into electricity.

Solar cells are made up of **silicon**, the same substance that makes up sand. Silicon is the second most common substance on Earth. Solar cells can supply energy to anything that is powered by batteries or electric power.

Electricity is produced when radiant energy from the sun strikes the solar cell, causing the electrons to move around. The action of the electrons starts an electric current. The conversion of sunlight into electricity takes place silently and instantly. There are no mechanical parts to wear out.

Compared to other ways of making electricity, photovoltaic systems are expensive and many panels are needed to equal the electricity generated at other types of plants.

It can cost 10 to 30 cents per kilowatt-hour to produce electricity from solar cells. Most people pay their electric companies about 12.7 cents per kilowatt-hour for the electricity they use, and large industrial consumers pay less. Solar systems are often used to generate electricity in remote areas that are a long way from electric power lines.

In 2015, the Desert Sunlight solar project in California opened. It is the largest photovoltaic plant in the world, generating 550 megawatts of electricity—enough to power over 150,000 homes.

### ■ Solar Thermal Electricity

Like solar cells, solar thermal systems, also called **concentrated solar power** (CSP), use solar energy to produce electricity, but in a different way. Most solar thermal systems use a solar collector with a mirrored surface to focus sunlight onto a receiver that heats a liquid. The super-heated liquid is used to make steam to produce electricity in the same way that coal plants do. There are CSP plants in California, Arizona, Nevada, Florida, Colorado, and Hawaii. Some of the world's largest CSP facilities are located in California.

Solar energy has great potential for the future. Solar energy is free, and its supplies are unlimited. It does not pollute or otherwise

## SOLAR WATER HEATER



## SOLAR PANELS (PHOTOVOLTAIC)



## SOLAR THERMAL ELECTRICITY



Image courtesy of U.S. Department of Energy

**Parabolic troughs concentrate the sun's radiant energy, heating fluid that is used to create steam. The steam turns a generator, which produces electricity.**

damage the environment. It cannot be controlled by any one nation or industry. If we can improve the technology to harness the sun's enormous power, we may never face energy shortages again.



# Uranium (Nuclear)

## What Is Nuclear Energy?

**Nuclear energy** is energy in the **nucleus** of an **atom**. Atoms are building blocks of **elements**. There is enormous energy in the bonds that hold atoms together.

Nuclear energy can be used to make electricity, but first the energy must be released. It can be released from atoms in two ways: nuclear fusion and fission.

In nuclear **fusion**, energy is released when atoms are combined or fused together to form a larger atom. This is how the sun produces energy.

In nuclear **fission**, atoms are split apart to form smaller atoms, releasing energy. Nuclear power plants use nuclear fission to produce electricity.

The fuel most widely used by nuclear plants for nuclear fission is **uranium**. Uranium is **nonrenewable**, though it is a common metal found in rocks all over the world. Nuclear plants use uranium as fuel because its atoms are easily split apart. During nuclear fission, a small particle called a **neutron** hits the uranium atom and the atom splits, releasing a great amount of energy as heat and radiation. More neutrons are also released. These neutrons go on to bombard other uranium atoms, and the process repeats itself over and over again. This is called a **chain reaction**.

## History of Nuclear Energy

Compared to other energy sources, fission is a very new way to produce energy. It wasn't until the early 1930s that scientists discovered that the nucleus of an atom is made up of particles called **protons** and neutrons.

A few years later, scientists discovered that the nucleus of an atom could be split apart by bombarding it with a neutron—the process we call fission. Soon they realized that enormous amounts of energy could be produced by nuclear fission.

During World War II, nuclear fission was first used to make a bomb. After the war, nuclear fission was used to generate electricity. Today, it provides 19.4 percent of the electricity used in the United States.

## How a Nuclear Plant Works

Most power plants burn fuel to produce electricity, but not nuclear power plants. Instead, nuclear plants use the heat given off during fission. Fission takes place inside the **reactor** of a nuclear power plant. At the center of the reactor is the core, which contains the uranium fuel.

The uranium fuel is formed into ceramic pellets. The pellets are about the size of your fingertip, but each one produces about the same amount of energy as 150 gallons (565 L) of oil. These energy-rich pellets are stacked end-to-end in 12-foot (3-4 m) metal **fuel rods**. A bundle of fuel rods is called a fuel assembly.

Fission generates thermal energy in a reactor just as coal generates thermal energy in a boiler. The thermal energy is used to boil water into steam. The steam turns huge **turbine** blades. As they turn, they drive **generators** that make electricity.

### Fission

The splitting of the nucleus of an atom into nuclei of lighter atoms, accompanied by the release of energy.

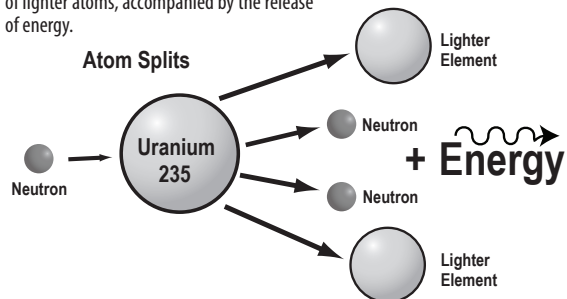

### Pressurized Water Reactor

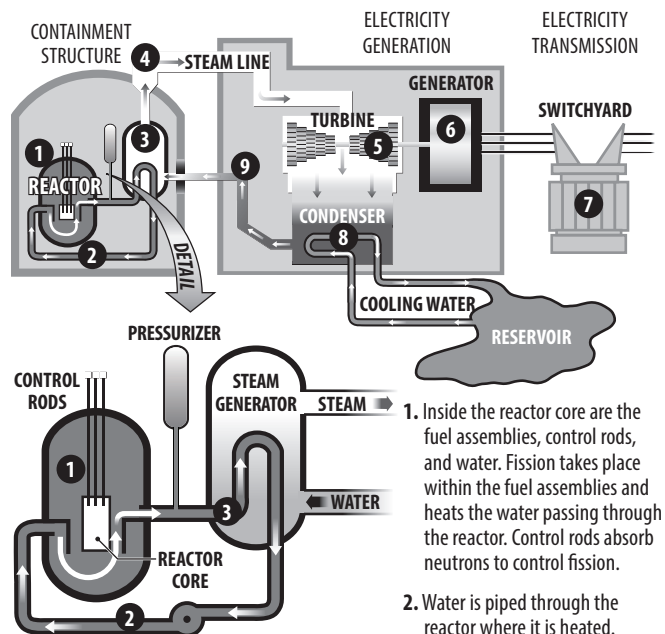

1. Inside the reactor core are the fuel assemblies, control rods, and water. Fission takes place within the fuel assemblies and heats the water passing through the reactor. Control rods absorb neutrons to control fission.
2. Water is piped through the reactor where it is heated.
3. It then travels to the steam generator where it heats a secondary system of water.
4. The steam generator keeps the steam at a high pressure. The steam travels through a steam line to the turbine.
5. The high pressure steam turns the turbine as it passes through, which spins a shaft. The steam then travels through the condenser where it is condensed by cooling water and is pumped back into the steam generator to repeat its cycle.
6. The turbine spins a shaft that travels into the generator. Inside the generator, the shaft spins coils of copper wire inside a ring of magnets. This generates electricity.
7. Electricity is sent to a switchyard, where a transformer increases the voltage, allowing it to travel through the electric grid.
8. The unused steam continues into the condenser where cool water from the environment (river, ocean, lake, reservoir) is used to condense it back into water. The cooling water never comes in direct contact with the steam, so it is safe to return to the environment.
9. The resulting water is pumped out of the condenser with a series of pumps, reheated and pumped back to the reactor vessel.



Afterward, the steam is changed back into water and cooled. Some plants use a local body of water for the cooling process; others use a separate structure at the power plant called a **cooling tower**.

## Spent (Used) Nuclear Fuel

Every few years, the fuel rods must be replaced. Fuel that has been removed from the reactor is called **spent fuel**. Nuclear power plants do not produce a large quantity of waste, but this used fuel is highly **radioactive**.

The spent fuel is usually stored near the reactor in a deep pool of water called the spent fuel pool. Here, the spent fuel cools down and begins to lose most of its radioactivity through a natural process called **radioactive decay**.

In three months, the spent fuel will have lost 50 percent of its radiation; in a year, it will have lost about 80 percent; and in ten years, it will have lost 90 percent. Nevertheless, because some radioactivity remains for as long as 1,000 years, the spent fuel must be carefully isolated from people and the environment.

## Spent Fuel Repository

Most scientists think the safest place to store nuclear waste is in underground rock formations called **repositories**. In 1982, Congress agreed and passed the Nuclear Waste Policy Act. This law directed the Department of Energy to design and build America's first repository.

The U.S. Department of Energy (DOE) originally looked at Yucca Mountain, Nevada, to be the site of a national spent nuclear fuel repository. Some people supported the site at Yucca Mountain and others did not. The DOE withdrew this location as a possible site, with intentions of pursuing a long-term solution. Until a final storage solution is found, nuclear power plants will continue storing spent fuel at their sites in spent fuel pools or dry cask storage.

## Nuclear Energy and the Environment

Nuclear power plants have very little impact on the environment unless there is an accident. Nuclear plants produce no air pollution or carbon dioxide, because no fuel is burned. Using nuclear energy may be one way to solve air pollution problems and reduce **greenhouse gas** emissions that contribute to global **climate change**.

Nuclear power plants do require a lot of water for cooling. If the water is taken from nearby rivers or lakes and returned at a higher temperature, it can disrupt the balance of organisms living in the water habitat.

The major challenge of nuclear power is storage of the radioactive spent fuel. Right now, all of the spent fuel is stored on site at the power plants. People also worry that an accident at a power plant could cause widespread damage and radioactive contamination.

People are using more and more electricity. Some experts predict that we will have to use nuclear energy to produce the amount of electricity people need at a cost they can afford.

## Nuclear Safety

The greatest potential risk from nuclear power plants is the release of high-level **radiation** and radioactive material. Radiation is energy given off by some elements and energy transformations. There are natural and man-made sources of radiation that we are exposed to everyday. Very small amounts of radiation are harmless to humans. Very high levels of radiation can damage or destroy the body's cells and can cause serious diseases such as cancer, or even death.

In the United States, plants are specifically designed to contain radiation and radioactive material in the unlikely case of an accident. Emergency plans are in place to alert and advise nearby residents if there is a release of radiation into the local environment. Nuclear power plants have harnessed the energy from the atom for over 50 years in the United States.

In 1979, at the Three Mile Island facility in Pennsylvania, the top half of the uranium fuel rods melted when coolant water to one reactor was cut off in error. A small amount of radioactive material escaped into the immediate area before the error was discovered. Due to the safety and containment features of the plant design, multiple barriers contained almost all of the radiation. No injuries or fatalities occurred as a result of the error.

In 1986, in the Ukraine (former Soviet Union) at the Chernobyl nuclear power plant, two steam explosions blew the top off of Unit 4. A lack of containment structures and other design flaws caused the release of a large amount of radioactive material into the local community. More than 100,000 people were evacuated from their homes and about 200 workers were treated for radiation sickness and burns. Several people were killed immediately, or died shortly after, with others suffering longer term medical ailments.

On March 11, 2011, an earthquake and resulting tsunami struck Japan, killing and injuring tens of thousands of people. Prior to the earthquake, Japan generated a large percentage of its electricity from nuclear power. In the Fukushima prefecture (community), the Daiichi nuclear plant shut down as a result of the earthquake but suffered extraordinary damage from the tsunami. The damage caused a loss of power that was required to keep the reactor and fuel rods cool. The release of some radioactive material required that residents within a 12 mile radius of the plant be evacuated. Residents living between 12 and 19 miles from the affected power plant were asked to evacuate voluntarily. The Japanese Nuclear and Industrial Safety Agency, the International Atomic Energy Agency, health organizations, and the nuclear energy industry continue to investigate the area and restore it for residents. These groups are also monitoring the impact of the radiation released from the Daiichi nuclear power plant both on the local environment and around the world.

Nuclear energy remains a major source of electricity in the United States and around the globe. The safe operation of nuclear power plants is important to quality of life and to the health and safety of individuals worldwide.



# Wind

## What Is Wind?

**Wind** is simply air in motion. It is caused by the uneven heating of the Earth's surface by radiant energy from the sun. Since the Earth's surface is made of very different types of land and water, it absorbs the sun's energy at different rates. Water usually does not heat or cool as quickly as land because of its physical properties.

An ideal situation for the formation of local wind is an area where land and water meet. During the day, the air above the land heats up more quickly than the air above water. The warm air over the land expands, becomes less dense and rises.

The heavier, denser, cool air over the water flows in to take its place, creating wind. In the same way, the atmospheric winds that circle the Earth are created because the land near the Equator is heated more by the sun than land near the North and South Poles.

Today, people use wind energy to make electricity. Wind is called a **renewable** energy source because the wind will blow as long as the sun shines. Wind only accounts for a small amount of U.S. energy consumption—less than two percent—but it is the fastest growing renewable source of energy, and accounts for almost five percent of U.S. electricity.

### Sea Breeze

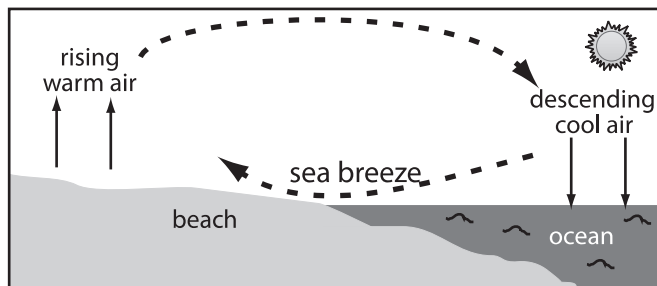

### Land Breeze

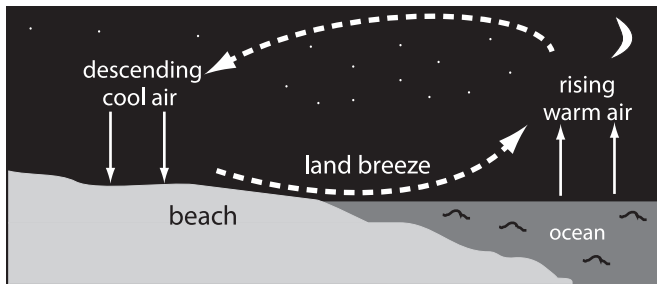

## Wind Direction

A weather vane, or wind vane, is used to show the direction of the wind. A wind vane points toward the source of the wind. Wind direction is reported as the direction from which the wind blows, not the direction toward which the wind moves. A north wind blows from the north toward the south.

## Wind Speed

It is important in many cases to know how fast the wind is blowing. Wind speed can be measured using a wind gauge or **anemometer**.

One type of anemometer is a device with three arms that spin on top of a shaft. Each arm has a cup on its end. The cups catch the wind and spin the shaft. The harder the wind blows, the faster the shaft spins. A device inside counts the number of rotations per minute and converts that figure into miles per hour. A display on the anemometer shows the speed of the wind.

## History of Wind Machines

Since ancient times, people have harnessed the wind's energy. Over 5,000 years ago, the ancient Egyptians used the wind to sail ships on the Nile River. Later, people built windmills to grind wheat and other grains. The early windmills looked like paddle wheels. Centuries later, the people in Holland improved the windmill. They gave it propeller-type blades, still made with sails. Holland is famous for its windmills.

In this country, the colonists used windmills to grind wheat and corn, to pump water, and to cut wood at sawmills. Today, people occasionally use windmills to grind grain and pump water, but they also use modern wind turbines to make electricity.

### Windmill



### Weather Vane

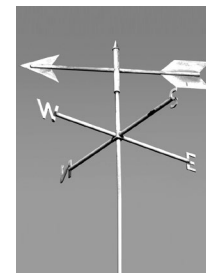

### Anemometer



## Today's Wind Turbines

Like old-fashioned windmills, today's **wind turbines** use blades to capture the wind's kinetic energy. Wind turbines work because they slow down the speed of the wind. When the wind blows, it pushes against the blades of the wind turbine, making the rotor spin. The parts of a turbine work together to power a generator to produce electricity.

Most wind turbines have the same basic parts: blades, shafts, gears, a generator, and a cable. (Some turbines do not have gear boxes.) These parts work together to convert the wind's energy into electricity.

1. The wind blows and pushes against the blades on top of the tower. The blades catch the wind and spin the rotor.
2. The rotor is connected to a low-speed shaft. When the rotor spins, the shaft turns. The shaft is connected to a gear box. The gears in the gear box increase the speed of the spinning motion on a high-speed shaft. All of the gears are housed inside the nacelle.
3. The high-speed shaft is connected to a generator. As the shaft turns inside the generator, it produces electricity.
4. The electricity is sent through cables down the turbine tower to a transformer and then to a transmission line.

The amount of electricity that a turbine produces depends on its size and the speed of the wind. Wind turbines come in many different sizes. A small turbine may power one home. Large wind turbines can produce enough electricity to power up to 1,000 homes. Large turbines are sometimes grouped together to provide power to the electricity grid. The grid is the network of power lines connected together across the entire country.

## Wind Power Plants

Wind power plants, or **wind farms**, are clusters of wind turbines used to produce electricity. A wind farm usually has dozens of wind turbines scattered over a large area.

Choosing the location of a wind farm is known as **siting** a wind farm. The wind speed and direction must be studied to determine where to put the turbines. As a rule, wind speed increases with height, as well as over open areas with no windbreaks.

Turbines are usually built in rows facing into the **prevailing wind**. Placing turbines too far apart wastes space. If turbines are too close together, they block each other's wind.

The site must have strong, steady winds. Scientists measure the winds in an area for several years before choosing a site. The best sites for wind farms are on hilltops, on the open plains, through mountain passes, and near the coasts of oceans or large lakes. Texas, the number one producer of wind energy in the U.S., has plentiful open space with steady winds. The Midwest and Rocky Mountain states are also prime states for wind energy production.

The wind blows stronger and steadier over water than over land. There are no obstacles on the water to block the wind. There is a lot of wind energy available **offshore**.

Offshore wind farms are built in the shallow waters off the coast of major lakes and oceans. Offshore turbines produce more electricity than turbines on land, but they cost more to build and operate.

## Wind Turbine Diagram

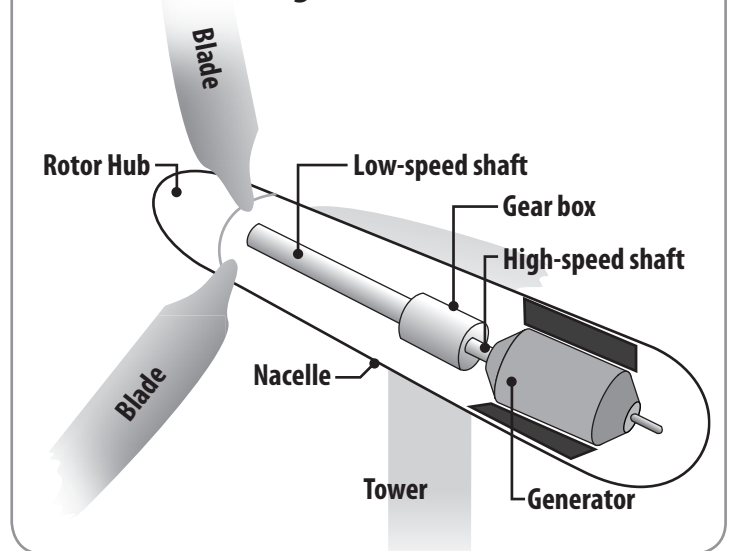

## WIND FARM



The first offshore wind farm in the United States, off the coast of Block Island, Rhode Island, began operating in 2016. It includes five turbines that power 17,000 homes.

## Wind Production

Every year, wind produces only a small amount of the electricity this country uses, but the amount is growing every year. One reason wind farms don't produce more electricity is that they can only run when the wind is blowing at certain speeds. On Midwestern wind farms, the wind is optimum for producing electricity between 65 and 90 percent of the time.

## Environmental Impacts

In some areas, people worry about the birds and bats that may be injured by wind turbines. Some people believe wind turbines produce a lot of sound, and some think turbines affect their view of the landscape.

On the other hand, wind is a clean, renewable energy source that produces no air pollution. And wind is free to use. Wind power may not be the perfect answer to our electricity needs, but it is a valuable part of the solution.



# Climate Change

## Earth's Atmosphere

Our Earth is surrounded by a blanket of gases called the **atmosphere**. Without this blanket, our Earth would be so cold that almost nothing could live. It would be a frozen planet. Our atmosphere keeps us alive and warm.

The atmosphere is made up of many different gases. Most of the atmosphere (99 percent) is oxygen and nitrogen. Less than half of one percent is a mixture of **greenhouse gases**. Greenhouse gases include water vapor, **carbon dioxide (CO<sub>2</sub>)**, **methane**, **F-gases**, **ozone**, and nitrous oxide. Water vapor is the most common greenhouse gas, but can have varying levels of concentration depending on the climate.

Carbon dioxide is the gas we produce when we breathe and when we burn wood and fossil fuels. Methane is the main gas in natural gas. It is also produced when once-living matter decays, and from animal waste. The other greenhouse gases are produced by burning fuels and from other natural and human activity.

## Sunlight and the Atmosphere

Rays of sunlight (**radiant energy**) shine down on the Earth every day. Some of these rays bounce off clouds and are reflected back into space. Some rays are absorbed by molecules in the atmosphere. About half of the sunlight passes through the atmosphere and reaches the Earth.

When the sunlight hits the Earth, most of it turns into thermal energy (heat). The Earth absorbs some of this thermal energy. The rest flows back out toward the atmosphere. This keeps the Earth from getting too warm.

When this thermal energy reaches the atmosphere, it stops. It can't pass through the atmosphere like sunlight. Most of the heat becomes trapped and flows back to the Earth. We usually think it's sunlight that warms the Earth, but actually it's this contained thermal energy that gives us most of our warmth.

## The Greenhouse Effect

We call this trapping of thermal energy the **greenhouse effect**. A greenhouse is a building made of clear glass or plastic. In cold weather, we can grow plants in a greenhouse. The glass allows the sunlight into the greenhouse. The sunlight turns into heat when it hits objects inside. The heat becomes trapped. The radiant energy can pass through the glass; the thermal energy cannot.

## The Greenhouse Effect

Radiant energy (light rays) shines on the Earth. Some radiant energy reaches the atmosphere and is reflected back into space. Some radiant energy is absorbed by the atmosphere and is transformed into thermal energy (heat) (dark arrows).

Half of the radiant energy that is directed at Earth passes through the atmosphere and reaches the Earth, where it is transformed into heat.

The Earth absorbs some of this heat.

Most of the heat flows back into the air. The atmosphere traps the heat.

Very little of the heat escapes back into space.

The trapped heat flows back to Earth.

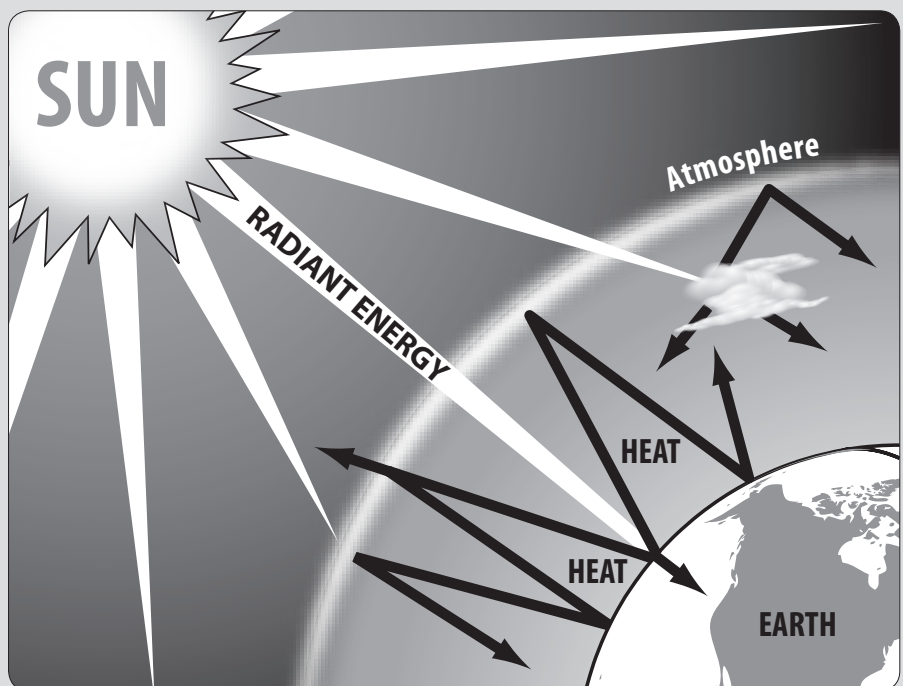



## Greenhouse Gases

What is in the atmosphere that lets light through, but traps heat? It's the greenhouse gases, mostly carbon dioxide and methane. These gases are very good at absorbing thermal energy and sending it back to Earth.

In the last 50 years, the amount of some greenhouse gases in the atmosphere has increased dramatically. We produce carbon dioxide when we breathe and when we burn wood and fossil fuels such as coal, oil, natural gas, and propane. Since the Industrial Revolution, CO<sub>2</sub> levels have risen by over 46 percent.

Some methane escapes from coal mines and oil wells. Some is produced when plants and garbage decay. Some animals also produce methane gas. Worldwide, grazing, plant-feeding animals, like cattle and goats, are one of the largest methane sources.

## Global Climate Change

Scientists all over the world are studying the effects of increased levels of greenhouse gases in the Earth's atmosphere. The overwhelming majority of scientists agree the greenhouse gases are trapping more heat in the atmosphere as levels increase. They believe the average temperature of the Earth is beginning to rise. This phenomenon is called **global warming**.

Scientists at NASA, the National Aeronautics and Space Administration, have found that the average temperature of the Earth has risen about 0.83°C (about 1.4°F) since 1880. They believe this increase in global temperature is the major cause of a 17 centimeter rise in the sea level over the same period of time.

Climate change experts predict that if the temperature of the Earth rises just a few degrees Fahrenheit, it will cause major changes in the world's climate. They predict there will be more floods in some places and more droughts in others. They believe the level of the oceans will rise as the ice at the North and South Poles melts. They think there might be stronger storms and hurricanes.

These scientists believe that countries all over the world need to act now to lower the amount of carbon dioxide that is emitted into the atmosphere. They believe we should reduce the amount of fossil fuels that we burn. The solutions being implemented include reducing CO<sub>2</sub> emissions from transportation and electricity by switching to less carbon intensive fuels. Experts around the world are trying to find ways to lower greenhouse gas emissions without causing major impacts on the economy.

### U.S. GREENHOUSE GAS EMISSIONS, 2014

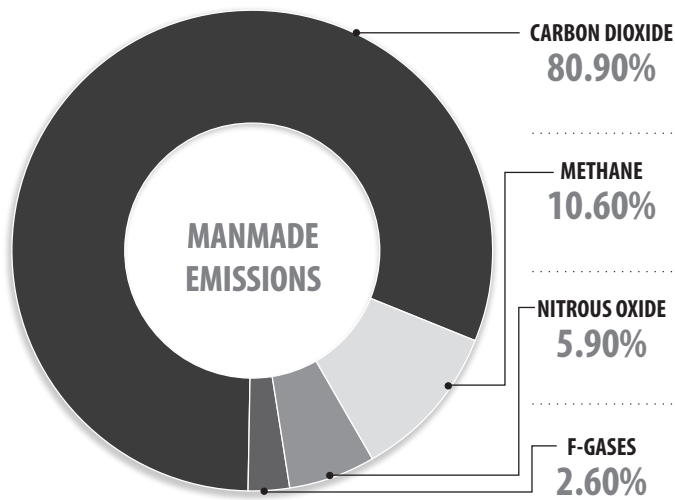

### SOURCES

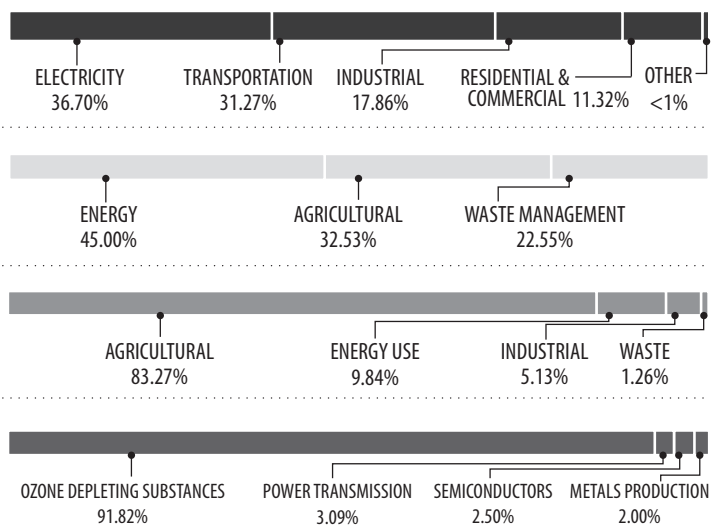

Data: U.S. Environmental Protection Agency

\*F-gases include HCFCs, PFCs, and SF<sub>6</sub>, which are used in many different industrial applications, including refrigerants, propellants, and tracer chemicals.

\*\*EPA is not reporting more recent data on emissions presently.

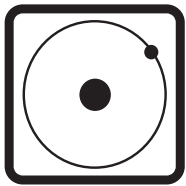

# Hydrogen

## What Is Hydrogen?

**Hydrogen** is the simplest element known to man. Each atom of hydrogen has only one proton and one electron. It is also the most plentiful gas in the universe. Stars are made primarily of hydrogen.

Like all stars, our sun's energy comes from hydrogen. The sun is a giant ball of hydrogen and helium gases. Inside the sun, hydrogen atoms combine to form helium atoms. This process, called **fusion**, gives off **radiant energy**.

This radiant energy sustains life on Earth. It gives us light and makes plants grow. It makes the wind blow and rain fall. It is stored in fossil fuels. Most of the energy we use today came from the sun.

Hydrogen as a gas ( $H_2$ ) doesn't exist on Earth. It is always mixed with other elements. Combined with oxygen, it is water ( $H_2O$ ). Combined with carbon, it makes different compounds such as methane ( $CH_4$ ), coal, and petroleum. Hydrogen is also found in all growing things—biomass.

Hydrogen has the highest energy content of any common fuel by weight, but the lowest energy content by volume. It is the lightest element and is a gas at normal temperature and pressure.

## Hydrogen Can Store Energy

Most of the energy we use comes from fossil fuels. Only about nine percent comes from **renewable** energy sources. They are usually cleaner and can be replenished in a short period of time.

Renewable energy sources—like solar and wind—can't produce energy all the time. The sun doesn't always shine. The wind doesn't always blow. Renewables don't always make energy when or where we need it. We can use many energy sources to produce hydrogen. Hydrogen can store the energy until it's needed and move it to where it's needed.

## Energy Carrier

Every day, we use more energy, mostly coal, to make electricity. Electricity is a **secondary source of energy**. Secondary sources of energy—sometimes called **energy carriers**—store, move, and deliver energy to consumers. We convert energy to electricity because it is easier for us to move and use.

Electricity gives us light, heat, hot water, cold food, TVs, and computers. Life would be really hard if we had to burn the coal, split the atoms, or build our own dams. Energy carriers make life easier.

Hydrogen is an energy carrier. It is a clean fuel that can be used for transportation, heating, and generating. However, since hydrogen doesn't exist on Earth as a gas, we must make it.

## THE SPACE SHUTTLE

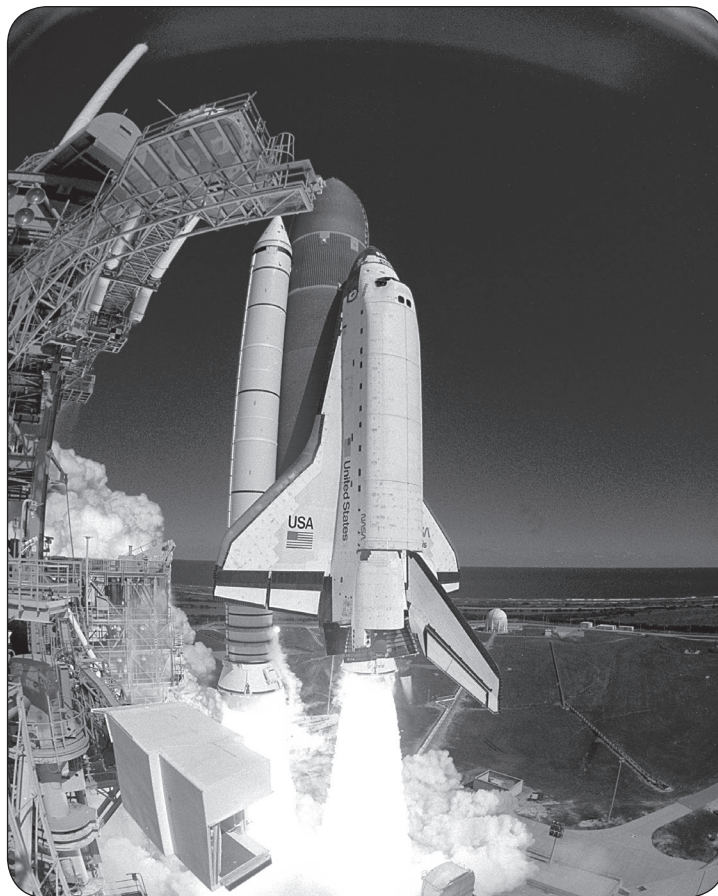
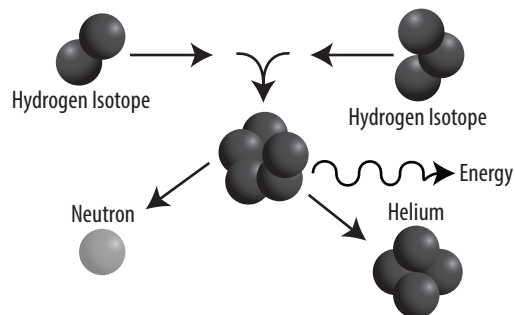

Image courtesy NASA

**NASA once used hydrogen to fuel the space shuttle. Hydrogen batteries—called fuel cells—powered the shuttle's electrical systems.**

## Fusion

The process of fusion most commonly involves hydrogen isotopes combining to form a helium atom with a transformation of matter. This matter is emitted as radiant energy.



## Hydrogen Fuel Cell

A fuel cell consists of an electrolyte membrane sandwiched between two catalyst-coated electrodes (anode and cathode). Oxygen (air) passes through one electrode and hydrogen through the other, generating electricity, water, and heat.

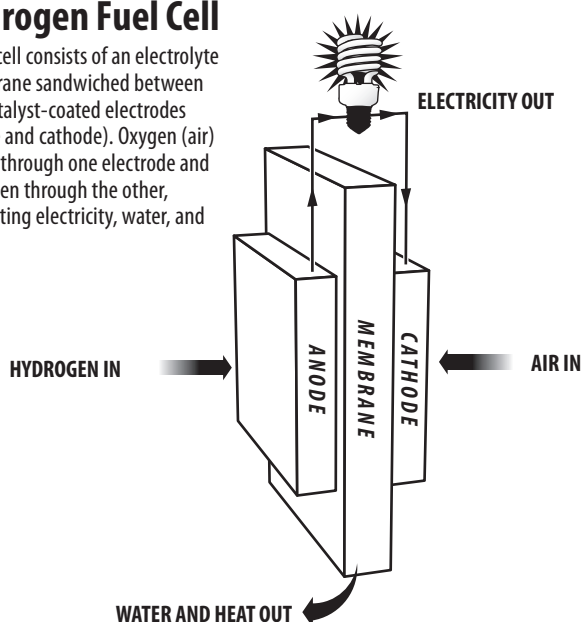

## Hydrogen Life Cycle

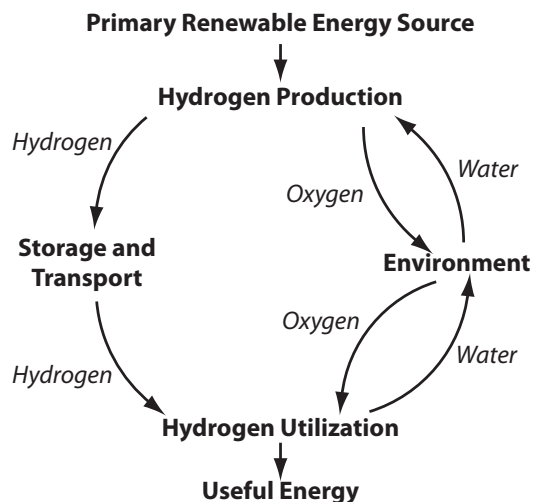

## How Is Hydrogen Made?

Hydrogen is made by separating it from water, biomass, or natural gas—from domestic resources. Scientists have even discovered that some algae and bacteria give off hydrogen. It is expensive to make hydrogen right now, but new technologies are being developed.

Hydrogen can be produced at large central facilities or at small plants for local use. Every region of the country (and the world) has some resource that can be used to make hydrogen. Its flexibility is one of its main advantages.

## Uses of Hydrogen

Several million cubic feet of hydrogen are produced in the U.S. each day. Most of this hydrogen is used by industry in refining, treating metals, and processing foods.

NASA was once the primary user of hydrogen as an energy fuel; it used hydrogen for years in the space program. Hydrogen fuel was used to lift the space shuttle into orbit. Hydrogen batteries—called **fuel cells**—powered the shuttle's electrical systems. The only by-product was pure water, which the crew used as drinking water.

Hydrogen fuel cells make electricity. They are very efficient, but expensive to build. Small fuel cells can power electric cars. Large fuel cells can provide electricity in remote areas.

## Hydrogen as a Fuel

Because of cost, storage, and distribution concerns, hydrogen power plants may not be built for a while. Hydrogen may soon be added to natural gas though, to reduce pollution from existing plants.

Soon hydrogen will be added to gasoline to boost performance and reduce pollution. Adding just five percent hydrogen to gasoline can significantly lower emissions of nitrogen oxides ( $\text{NO}_x$ ), which contribute to ground-level ozone pollution.

## HYDROGEN-FUELED VEHICLE



Image courtesy U.S. Department of Energy

An engine that burns pure hydrogen produces almost no pollution. It will be a while though before you can walk into your local car dealer and drive away in a hydrogen-powered car.

## The Future of Hydrogen

Before hydrogen becomes a significant fuel in the U.S. energy picture, many new systems must be built. We will need systems to produce hydrogen efficiently and to store and move it safely. We will need many miles of new pipelines and economical fuel cells. Consumers will need the technology and the education to use it.

With advancements in hydrogen and fuel cell technologies, hydrogen has the potential to provide a large amount of clean, renewable energy in the future.



# Electricity

## Electricity: The Mysterious Force

What exactly is the mysterious force we call electricity? It is simply moving **electrons**. And what exactly are electrons? They are tiny particles found in **atoms**.

Everything in the universe is made of atoms—every star, every tree, every animal. The human body is made of atoms. Air and water are, too. Atoms are the building blocks of the universe. There are over 100 different types of atoms found in the world around us that make up elements. Each element is identified and organized into the periodic table. Atoms of these elements are so small that millions of them would fit on the head of a pin.

Atoms are made of even smaller particles. The center of an atom is called the **nucleus**. It is made of particles called **protons** and **neutrons**. The protons and neutrons are very small, but electrons are much, much smaller. Electrons spin around the nucleus in energy

levels a great distance from the nucleus. If the nucleus were the size of a tennis ball, the atom would be several kilometers in diameter. Atoms are mostly empty space.

If you could see an atom, it would look a little like a tiny center of spheres surrounded by giant invisible clouds. The electrons would be on the surface of the clouds, constantly spinning and moving to stay as far away from each other as possible on their **energy levels**. Electrons are held in their levels by an electrical force.

The protons and electrons of an atom are attracted to each other. They both carry an **electric charge**. An electric charge is a force within the particle. Protons have a positive charge (+) and electrons have a negative charge (-). The positive charge of the protons is equal to the negative charge of the electrons. Opposite charges attract each other. When an atom is in balance, it has an equal number of protons and electrons. Neutrons carry no charge, and their number can vary.

## The Periodic Table of the Elements

Group																		18																																																																
1		2												13		14	15	16	17	18																																																														
IA		IIA												IIIA		IVA	VA	VIA	VIIA	VIIIA																																																														
1	<b>H</b> Hydrogen 1.00794																				2	<b>He</b> Helium 4.002602																																																												
2	<b>Li</b> Lithium 6.941	<b>Be</b> Beryllium 9.012182											<b>B</b> Boron 10.811		<b>C</b> Carbon 12.0107	<b>N</b> Nitrogen 14.0067	<b>O</b> Oxygen 15.9994	<b>F</b> Fluorine 18.9984032	<b>Ne</b> Neon 20.1797																																																															
3	<b>Na</b> Sodium 22.989770	<b>Mg</b> Magnesium 24.3050											<b>Al</b> Aluminum 26.981538		<b>Si</b> Silicon 28.0855	<b>P</b> Phosphorus 30.973761	<b>S</b> Sulfur 32.065	<b>Cl</b> Chlorine 35.453	<b>Ar</b> Argon 39.948																																																															
4	<b>K</b> Potassium 39.0983	<b>Ca</b> Calcium 40.078	<b>Sc</b> Scandium 44.955910	<b>Ti</b> Titanium 47.867	<b>V</b> Vanadium 50.9415	<b>Cr</b> Chromium 51.9961	<b>Mn</b> Manganese 54.938049	<b>Fe</b> Iron 55.845	<b>Co</b> Cobalt 58.933200	<b>Ni</b> Nickel 58.6934	<b>Cu</b> Copper 63.546	<b>Zn</b> Zinc 65.409	<b>Ga</b> Gallium 69.723	<b>Ge</b> Germanium 72.64	<b>As</b> Arsenic 74.92160	<b>Se</b> Selenium 78.96	<b>Br</b> Bromine 79.904	<b>Kr</b> Krypton 83.798																																																																
5	<b>Rb</b> Rubidium 85.4678	<b>Sr</b> Strontium 87.62	<b>Y</b> Yttrium 88.90585	<b>Zr</b> Zirconium 91.224	<b>Nb</b> Niobium 92.90638	<b>Mo</b> Molybdenum 95.94	<b>Tc</b> Technetium (98)	<b>Ru</b> Ruthenium 101.07	<b>Rh</b> Rhodium 102.90550	<b>Pd</b> Palladium 106.42	<b>Ag</b> Silver 107.8682	<b>Cd</b> Cadmium 112.411	<b>In</b> Indium 114.818	<b>Sn</b> Tin 118.710	<b>Sb</b> Antimony 121.760	<b>Te</b> Tellurium 127.60	<b>I</b> Iodine 126.90447	<b>Xe</b> Xenon 131.293																																																																
6	<b>Cs</b> Cesium 132.90545	<b>Ba</b> Barium 137.327	<b>Hf</b> Hafnium 178.49	<b>Ta</b> Tantalum 180.9479	<b>W</b> Tungsten 183.84	<b>Re</b> Rhenium 186.207	<b>Os</b> Osmium 190.23	<b>Ir</b> Iridium 192.217	<b>Pt</b> Platinum 195.078	<b>Au</b> Gold 196.96655	<b>Hg</b> Mercury 200.59	<b>Tl</b> Thallium 204.3833	<b>Pb</b> Lead 207.2	<b>Bi</b> Bismuth 208.98038	<b>Po</b> Polonium (209)	<b>At</b> Astatine (210)	<b>Rn</b> Radon (222)																																																																	
7	<b>Fr</b> Francium (223)	<b>Ra</b> Radium (226)	<b>Rf</b> Rutherfordium (261)	<b>Db</b> Dubnium (262)	<b>Sg</b> Seaborgium (266)	<b>Bh</b> Bohrium (264)	<b>Hs</b> Hassium (277)	<b>Mt</b> Meitnerium (268)	<b>Ds</b> Darmstadtium (281)	<b>Rg</b> Roentgenium (280)	<b>Cn</b> Copernicium (285)	<b>Uut</b> Ununtrium (284)	<b>Fl</b> Flerovium (289)	<b>Mc</b> Moscovium (288)	<b>Lv</b> Livermorium (293)	<b>Ts</b> Tennessine (294)	<b>Og</b> Oganesson (294)																																																																	
			<table border="1"> <tr> <td colspan="16">Lanthanides</td> </tr> <tr> <td><b>57 La</b> Lanthanum 138.9055</td> <td><b>58 Ce</b> Cerium 140.116</td> <td><b>59 Pr</b> Praseodymium 140.90765</td> <td><b>60 Nd</b> Neodymium 144.24</td> <td><b>61 Pm</b> Promethium (145)</td> <td><b>62 Sm</b> Samarium 150.36</td> <td><b>63 Eu</b> Europium 151.964</td> <td><b>64 Gd</b> Gadolinium 157.25</td> <td><b>65 Tb</b> Terbium 158.92534</td> <td><b>66 Dy</b> Dysprosium 162.500</td> <td><b>67 Ho</b> Holmium 164.93032</td> <td><b>68 Er</b> Erbium 167.259</td> <td><b>69 Tm</b> Thulium 168.93421</td> <td><b>70 Yb</b> Ytterbium 173.04</td> <td><b>71 Lu</b> Lutetium 174.967</td> <td colspan="1"></td> </tr> <tr> <td colspan="16">Actinides</td> </tr> <tr> <td><b>89 Ac</b> Actinium (227)</td> <td><b>90 Th</b> Thorium 232.0381</td> <td><b>91 Pa</b> Protactinium 231.03588</td> <td><b>92 U</b> Uranium 238.02891</td> <td><b>93 Np</b> Neptunium (237)</td> <td><b>94 Pu</b> Plutonium (244)</td> <td><b>95 Am</b> Americium (243)</td> <td><b>96 Cm</b> Curium (247)</td> <td><b>97 Bk</b> Berkelium (247)</td> <td><b>98 Cf</b> Californium (251)</td> <td><b>99 Es</b> Einsteinium (252)</td> <td><b>100 Fm</b> Fermium (257)</td> <td><b>101 Md</b> Mendelevium (258)</td> <td><b>102 No</b> Nobelium (259)</td> <td><b>103 Lr</b> Lawrencium (262)</td> <td colspan="1"></td> </tr> </table>																Lanthanides																<b>57 La</b> Lanthanum 138.9055	<b>58 Ce</b> Cerium 140.116	<b>59 Pr</b> Praseodymium 140.90765	<b>60 Nd</b> Neodymium 144.24	<b>61 Pm</b> Promethium (145)	<b>62 Sm</b> Samarium 150.36	<b>63 Eu</b> Europium 151.964	<b>64 Gd</b> Gadolinium 157.25	<b>65 Tb</b> Terbium 158.92534	<b>66 Dy</b> Dysprosium 162.500	<b>67 Ho</b> Holmium 164.93032	<b>68 Er</b> Erbium 167.259	<b>69 Tm</b> Thulium 168.93421	<b>70 Yb</b> Ytterbium 173.04	<b>71 Lu</b> Lutetium 174.967		Actinides																<b>89 Ac</b> Actinium (227)	<b>90 Th</b> Thorium 232.0381	<b>91 Pa</b> Protactinium 231.03588	<b>92 U</b> Uranium 238.02891	<b>93 Np</b> Neptunium (237)	<b>94 Pu</b> Plutonium (244)	<b>95 Am</b> Americium (243)	<b>96 Cm</b> Curium (247)	<b>97 Bk</b> Berkelium (247)	<b>98 Cf</b> Californium (251)	<b>99 Es</b> Einsteinium (252)	<b>100 Fm</b> Fermium (257)	<b>101 Md</b> Mendelevium (258)	<b>102 No</b> Nobelium (259)	<b>103 Lr</b> Lawrencium (262)	
Lanthanides																																																																																		
<b>57 La</b> Lanthanum 138.9055	<b>58 Ce</b> Cerium 140.116	<b>59 Pr</b> Praseodymium 140.90765	<b>60 Nd</b> Neodymium 144.24	<b>61 Pm</b> Promethium (145)	<b>62 Sm</b> Samarium 150.36	<b>63 Eu</b> Europium 151.964	<b>64 Gd</b> Gadolinium 157.25	<b>65 Tb</b> Terbium 158.92534	<b>66 Dy</b> Dysprosium 162.500	<b>67 Ho</b> Holmium 164.93032	<b>68 Er</b> Erbium 167.259	<b>69 Tm</b> Thulium 168.93421	<b>70 Yb</b> Ytterbium 173.04	<b>71 Lu</b> Lutetium 174.967																																																																				
Actinides																																																																																		
<b>89 Ac</b> Actinium (227)	<b>90 Th</b> Thorium 232.0381	<b>91 Pa</b> Protactinium 231.03588	<b>92 U</b> Uranium 238.02891	<b>93 Np</b> Neptunium (237)	<b>94 Pu</b> Plutonium (244)	<b>95 Am</b> Americium (243)	<b>96 Cm</b> Curium (247)	<b>97 Bk</b> Berkelium (247)	<b>98 Cf</b> Californium (251)	<b>99 Es</b> Einsteinium (252)	<b>100 Fm</b> Fermium (257)	<b>101 Md</b> Mendelevium (258)	<b>102 No</b> Nobelium (259)	<b>103 Lr</b> Lawrencium (262)																																																																				



## Carbon Atom

A carbon atom has six protons and six neutrons in the nucleus, two electrons in the inner energy level, and four electrons in the outer energy level.

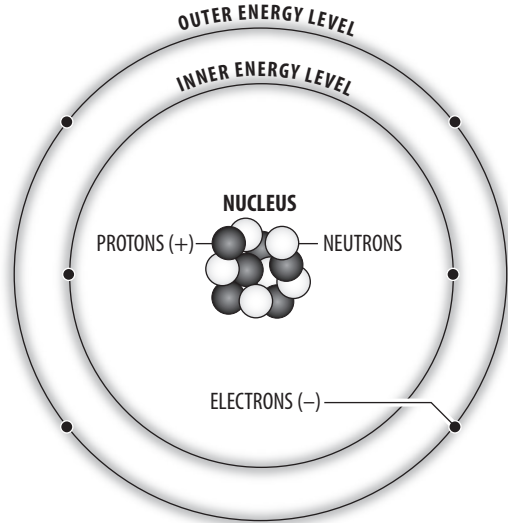

The number of protons in an atom determines the kind of atom, or **element**, it is. An element is a substance in which all of the atoms are identical. An atom of hydrogen, for example, has one proton and one electron, and almost always no neutrons. Every stable atom of carbon has six protons, six electrons, and typically six neutrons. The number of protons is also called the **atomic number**. The atomic number is used to identify an element.

Electrons usually remain a relatively constant distance from the nucleus in well defined regions called energy levels. The level closest to the nucleus can hold two electrons. The next level can hold up to eight. The outer levels can hold even more. Some atoms with many protons can have as many as seven levels with electrons in them.

The electrons in the levels closest to the nucleus have a strong force of attraction to the protons. Sometimes, the electrons in the outermost levels do not. These electrons can be pushed out of their orbits. Applying a force can make them move from one atom to another. These moving electrons are electricity.

## Magnets

In most objects the molecules that make up the substance have atoms with electrons that spin in random directions. They are scattered evenly throughout the object. **Magnets** are different—they are made of molecules that have north- and south-seeking poles.

The molecules in a magnet are arranged so that most of the north-seeking poles point in one direction and most of the south-seeking poles point in the other.

Spinning electrons create small **magnetic fields** and act like microscopic magnets or micro-magnets. In most objects, the electrons located around the nucleus of the atoms spin in random directions throughout the object. This means the micro-magnets all point in random directions cancelling out their magnetic fields.

## Bar Magnet

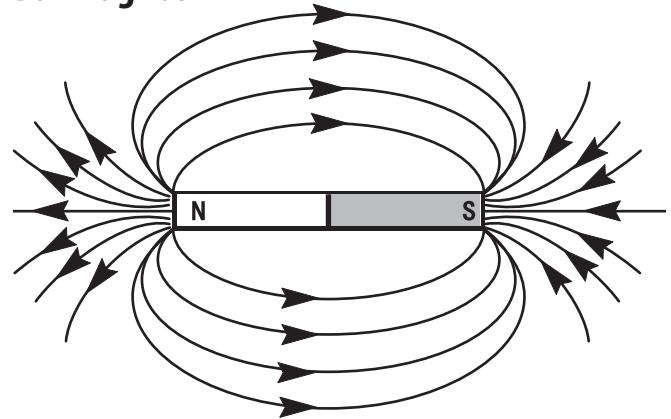

## Like Poles

Like poles of magnets (N-N or S-S) repel each other.

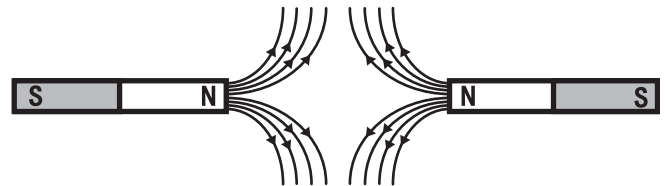

## Opposite Poles

Opposite poles of magnets (N-S) attract each other.

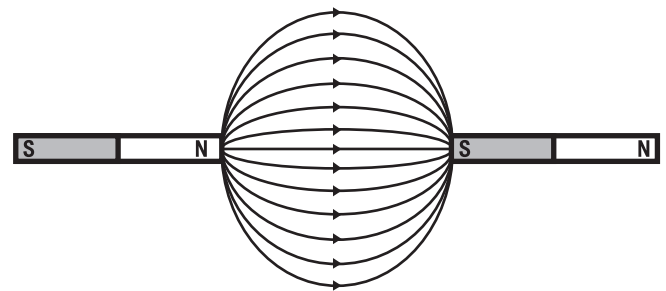

Magnets are different—most of the atoms' electrons spin in the same direction, which means the north- and south-seeking poles of the micro-magnets they create are aligned. Each micro-magnet works together to give the magnet itself a north- and south-seeking pole.

A magnet is often labelled with north (N) and south (S) poles. The magnetic force in a magnet flows from the north pole to the south pole.

Have you ever held two magnets close to each other? They don't act like most objects. If you try to push the south poles together, they repel each other. The two north poles also repel each other.

If you turn one magnet around, the north and the south poles are attracted to each other. The magnets come together with a strong force. Just like protons and electrons, opposites attract.



# Electricity

## Magnets Can Produce Electricity

We can use magnets to make electricity. A magnetic field can move electrons. Some metals, like copper, have electrons that are loosely held; they are easily pushed from their levels.

Magnetism and electricity are related. Magnets can create electricity and electricity can produce magnetic fields. Every time a magnetic field changes, an electric field is created. Every time an electric field changes, a magnetic field is created. Magnetism and electricity are always linked together; you can't have one without the other. This phenomenon is called **electromagnetism**.

Power plants use huge turbine generators to make the electricity that we use in our homes and businesses. Power plants use many fuels to spin **turbines**. They can burn coal, oil, or natural gas to make steam to spin turbines. Or they can split uranium atoms to heat water into steam. They can also use the power of rushing water from a dam or the energy in the wind to spin the turbine.

The turbine is attached to a shaft in the generator. Inside the **generator** are magnets and coils of copper wire. The magnets and coils can be designed in two ways—the turbine can spin the magnets inside the coils or can spin coils inside the magnets. Either way, the electrons are pushed from one copper atom to another by the moving magnetic field.

Coils of copper wire are attached to the turbine shaft. The shaft spins the coils of wire inside two huge magnets. The magnet on one side has its north pole to the front. The magnet on the other side has its south pole to the front. The magnetic fields around these magnets push and pull the electrons in the copper wire as the wire spins. The electrons in the coil flow into transmission lines. These moving electrons are the electricity that flows to our houses. Electricity moves through the wire very quickly.

## Turbine Generator

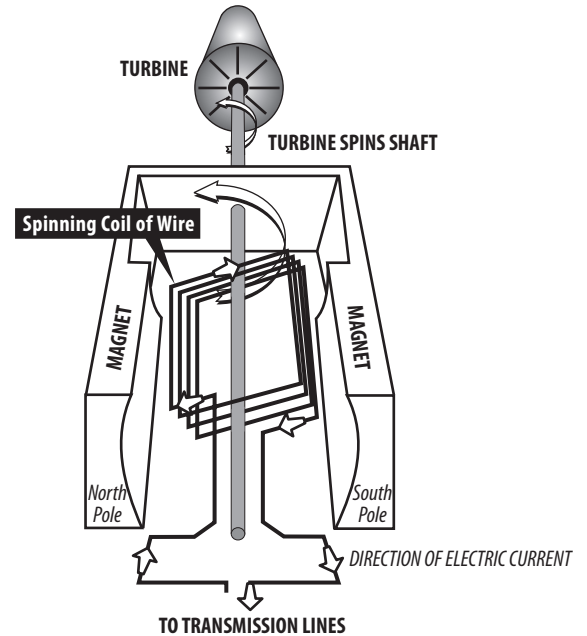

## HYDROPOWER TURBINE GENERATORS

### HYDROELECTRIC PLANT



Photo of Safe Harbor Water Power Corporation on the Lower Susquehanna River in Pennsylvania.

## Batteries Produce Electricity

A **battery** produces electricity using two different metals in a chemical solution. A **chemical reaction** between the metals and the chemicals frees more electrons in one metal than in the other.

One end of the battery is attached to one of the metals; the other end is attached to the other metal. The end that frees more electrons develops a positive charge, and the other end develops a negative charge because it attracts the free, negatively charged electrons. If a wire is attached from one end of the battery to the other, electrons flow through the wire to balance the electrical charge.

A **load** is a device that does work or performs a job. If a load—such as a light bulb—is placed along the wire, the electricity can do work as it flows through the wire. In the *Electric Circuits* diagram, electrons flow from the negative end of the battery through the wire to the light bulb. The electricity flows through the wire in the light bulb and back to the battery.

## Electricity Travels in Circuits

Electricity travels in closed loops, or **circuits**. It must have a complete path before the electrons can move. If a circuit is open, the electrons cannot flow. When we flip on a light switch, we close a circuit. The electricity flows from the electric wire through the light and back into the wire. When we flip the switch off, we open the circuit. No electricity flows to the light.

When we turn on the TV, electricity flows through wires inside the set, producing pictures and sound. Sometimes electricity runs motors—in washers or mixers. Electricity does a lot of work for us. We use it many times each day.

In the United States, we use electricity to light our homes, schools, and businesses. We use it to warm and cool our homes and help us clean them. Electricity runs our TVs, DVD players, video games, and computers. It cooks our food and washes the dishes. It mows our lawns and blows the leaves away. It can even run our cars.

## Electric Circuits

### FLOW OF ELECTRONS IN A CLOSED CIRCUIT

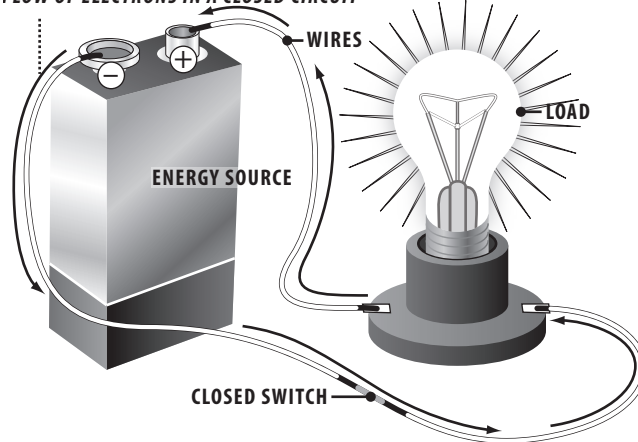

A closed circuit is a complete path allowing electricity to flow from the energy source to the load.

### FLOW OF ELECTRONS IN AN OPEN CIRCUIT

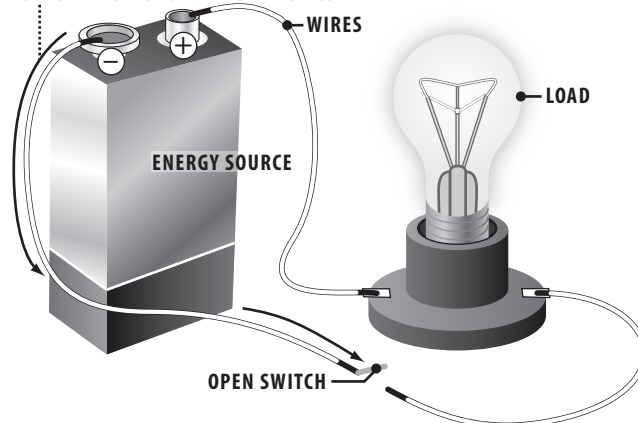

An open circuit has a break in the path. There is no flow of electricity because the electrons cannot complete the circuit.

## How an Electric Vehicle Works

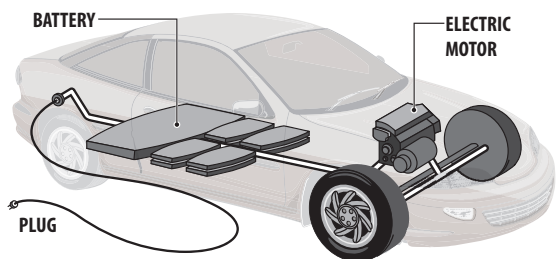

Recently, there has been more interest in using electricity to help reduce the amount of petroleum consumed by the transportation sector.

The plug-in hybrid electric vehicle (PHEV) and the dedicated electric vehicle (EV) are available to consumers in the open market. Many car manufacturers are offering PHEVs and EVs in more models.

As the diagram to the left shows, electric vehicles store electricity in large battery banks. They are plugged into a wall outlet (either a 240-volt or standard 120-volt) for several hours to charge. An electric motor powers the wheels, and acts as a generator when the brakes are applied, recharging the battery.





# Electricity

## Secondary Energy Source

Electricity is different from primary sources of energy. Unlike coal, petroleum, or solar energy, electricity is a **secondary source of energy**. That means we must use other energy sources to make electricity. It also means we can't classify electricity as renewable or nonrenewable.

Coal, which is nonrenewable, can be used to make electricity. So can hydropower, a renewable energy source. The energy source we use can be renewable or nonrenewable, but electricity is neither.

## Generating Electricity

Most of the electricity we use in the United States is generated by large power plants. These plants use many fuels to produce electricity. Thermal power plants use coal, biomass, petroleum, or natural gas to superheat water into steam, which powers a generator to produce electricity. Nuclear power plants use **fission** to produce the heat. Geothermal power plants use heat from inside the Earth. Wind farms use the kinetic energy in the wind to generate electricity, while hydropower plants use the energy in moving water.

## Moving Electricity

We use more electricity every year. One reason we use so much electricity is that it's easy to move from one place to another. It can be made at a power plant and moved long distances before it is used. There is also a standard system in place so that all of our machines and appliances can operate on electricity. Electricity makes our lives simpler and easier.

Let's follow the path of electricity from a power plant to a light bulb in your home. First, the electricity is generated at a power plant. It travels through a wire to a **transformer** that steps up, or increases, the **voltage**. Power plants step up the voltage because less electricity is lost along the power lines when it is at a higher voltage.

The electricity is then sent to a nationwide network of **transmission lines**. This is called the electric **grid**. Transmission lines are the huge tower lines you see along the highway. The transmission lines are interconnected, so if one line fails, another can take over the load.

Step-down transformers, located at **substations** along the lines, reduce the voltage from 350,000 volts to 12,000 volts. Substations are small fenced-in buildings that contain transformers, switches, and other electrical equipment.

The electricity is then carried over **distribution lines** that deliver electricity to your home. These distribution lines can be located overhead or underground. The overhead distribution lines are the power lines you see along streets.

Before the electricity enters your house, the voltage is reduced again at another transformer, usually a large gray metal box mounted on an electric pole. This transformer reduces the electricity to the 120 or 240 volts that are used to operate the appliances in your home.

Electricity enters your home through a three-wire cable. Wires are run from the circuit breaker or fuse box to outlets and wall switches in your home. An electric meter measures how much electricity you use so that the utility company can bill you.

## TRANSMISSION LINES



## Transporting Electricity

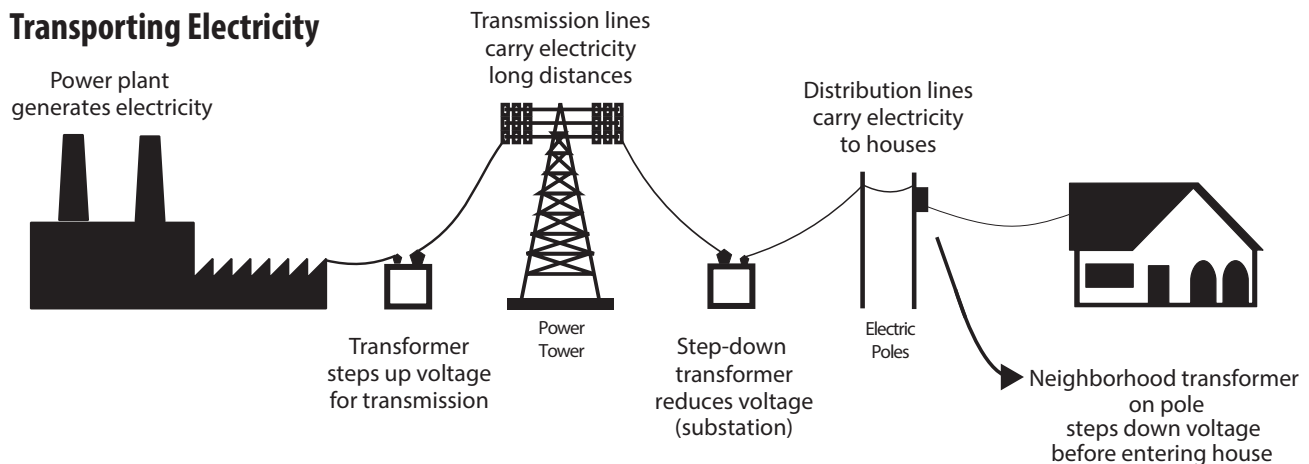



# Fuels that Make Electricity

Four kinds of power plants produce most of the electricity in the United States: coal, natural gas, nuclear, and hydropower. Coal plants generate about 33 percent of the electricity we use. There are also wind, geothermal, waste-to-energy, and solar power plants, which together generate less than ten percent of the electricity produced in the United States.

## ▪ Fossil Fuel Power Plants

**Fossil fuel** plants burn coal, natural gas, or oil to produce electricity. These energy sources are called fossil fuels because they were formed from the remains of ancient sea plants and animals. Most of our electricity comes from fossil fuel plants.

Power plants burn the fossil fuels and use the heat to boil water into steam. The steam is channeled through a pipe at high pressure to spin a turbine generator to make electricity. Fossil fuel power plants produce emissions that pollute the air and contribute to global climate change.

Fossil fuel plants are sometimes called thermal power plants because they use heat energy to make electricity. (*Therme* is the Greek word for heat.) Coal is used by most power plants because it is cheap and abundant in the United States.

There are many other uses for petroleum and natural gas, but the main use of coal is to produce electricity. About 91 percent of the coal mined in the United States is sent to power plants to make electricity.

## ▪ Nuclear Power Plants

Nuclear power plants are called thermal power plants, too. They produce electricity in much the same way as fossil fuel plants, except that the fuel they use is **uranium**, which isn't burned.

Uranium is a mineral found in rocks underground. A nuclear power plant splits the nuclei of uranium atoms to make smaller atoms in a process called **fission** that produces enormous amounts of thermal energy. The thermal energy is used to turn water into steam, which drives a turbine generator.

Nuclear power plants don't produce carbon dioxide emissions, but their waste is **radioactive**. Nuclear waste must be stored carefully to prevent contamination of people and the environment.

## ▪ Hydropower Plants

Hydropower plants use the energy in moving water to generate electricity. Fast-moving water is used to spin the blades of a turbine generator. Hydropower is called a **renewable** energy source because it is renewed by rainfall.

## Peak Demand

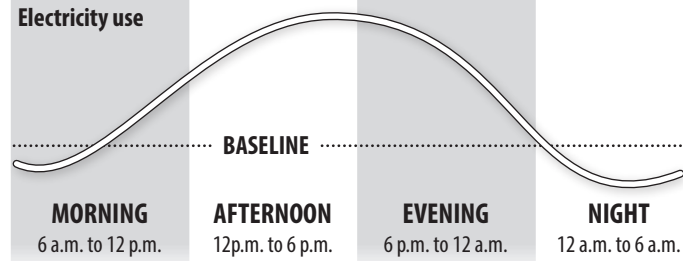

**Peak demand**, also called peak load, is the maximum load during a specified period of time.

## U.S. Electricity Net Generation, 2015

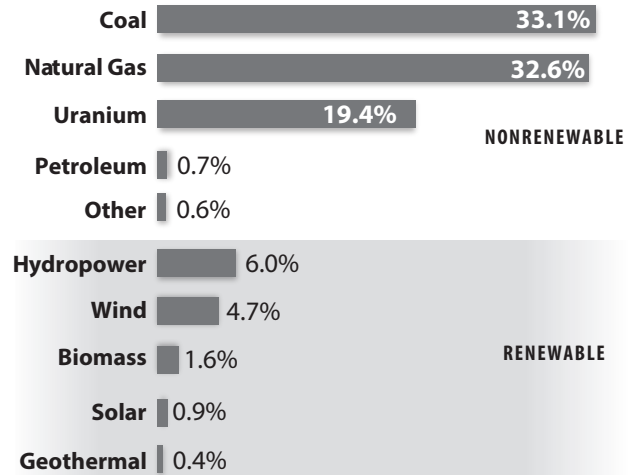

\*\* Other: non-biogenic waste, fossil fuel gases.  
Data: Energy Information Administration

## Thermal Power Plant

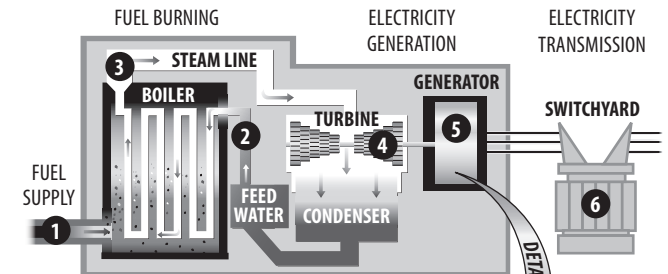

1. Fuel is fed into a boiler, where it is burned to release thermal energy.
2. Water is piped into the boiler and heated, turning it into steam.
3. The steam travels at high pressure through a steam line.
4. The high pressure steam turns a turbine, which spins a shaft.
5. Inside the generator, the shaft spins coils of copper wire inside a ring of magnets. This creates an electric field, producing electricity.
6. Electricity is sent to a switchyard, where a transformer increases the voltage, allowing it to travel through the electric grid.

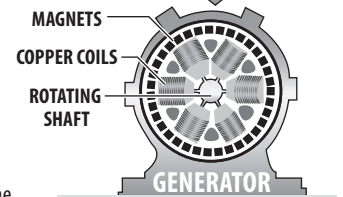



# Electricity

## What's a Watt?

We use electricity to perform many tasks. We use units called watts, kilowatts, and kilowatt-hours to measure the electricity that we use.

A **watt** is a measure of the electric power an appliance uses. Every appliance requires a certain number of watts to work correctly. Traditional light bulbs were rated by watts (60, 75, 100), as well as home appliances, such as a 1500-watt hairdryer. A **kilowatt** is 1,000 watts. It is used to measure larger amounts of electricity.

A **kilowatt-hour** (kWh) measures the amount of electricity used in one hour. Sometimes it's easier to understand these terms if you compare them to a car. A kilowatt is the *rate* of electric flow, or how much energy you are consuming at a specific instant. In a car, it would be similar to how fast you are driving at one instant. A kilowatt-hour is a quantity or amount of energy, or how much you consumed over a period of time. A kWh is like the distance traveled in a car.

We pay for the electricity we use in kilowatt-hours. Our power company sends us a bill for the number of kilowatt-hours we use every month. Most residential consumers in the United States pay about 12.7 cents per kilowatt-hour of electricity. In 2015, Washington state residents paid the least for electricity: 9.1 cents per kilowatt-hour. Hawaii residents paid the most: between 24 to 33 cents per kilowatt-hour, depending on the island.

## Cost of Electricity

How much does it cost to make electricity? It depends on several factors, such as:

- **Fuel Cost:** The major cost of generating electricity is the cost of the fuel. Many energy sources can be used. Hydropower is the cheapest way while solar cells are usually the most expensive way to generate power.
- **Building Cost:** Another key is the cost of building the power plant itself. A plant may be very expensive to build, but the low cost of the fuel can make the electricity economical to produce. Nuclear power plants, for example, are very expensive to build, but their fuel—uranium—is inexpensive. Coal-fired plants, on the other hand, are cheaper to build, but their fuel—coal—is more expensive.
- **Efficiency:** When figuring cost, you must also consider a plant's efficiency. Efficiency is the amount of useful energy you get out of a system. A totally efficient machine would change all the energy put in it into useful work. Changing one form of energy into another always involves a loss of usable energy.

In general, today's power plants use three units of fuel to produce one unit of electricity. Most of the lost energy is waste heat. You can see this waste heat in the great clouds of steam pouring out of giant cooling towers on some power plants. A typical coal plant burns about 4,500 tons of coal each day. About two-thirds of the chemical energy in the coal (3,000 tons) is lost as it is converted first to thermal energy, and then to motion energy, and finally into electrical energy.

## How Much Is a Watt?



**1 WATT**  
Small, LED flashlight



**1.5 KILOWATTS = 1500 WATTS**  
Blow dryer



**3 TO 5 MEGAWATTS =**  
**3,000,000 to 5,000,000 WATTS**  
Diesel-electric locomotive engines



**2 GIGAWATTS =**  
**2,000,000,000 WATTS**  
Peak output of the Hoover Dam

## Average Residential Price for Electricity, 2015

PRICE PER KILOWATT-HOUR

- < 10¢ / kWh
- 10 to 11¢ / kWh
- 11 to 12¢ / kWh
- 12 to 15¢ / kWh
- > 15.00¢ / kWh

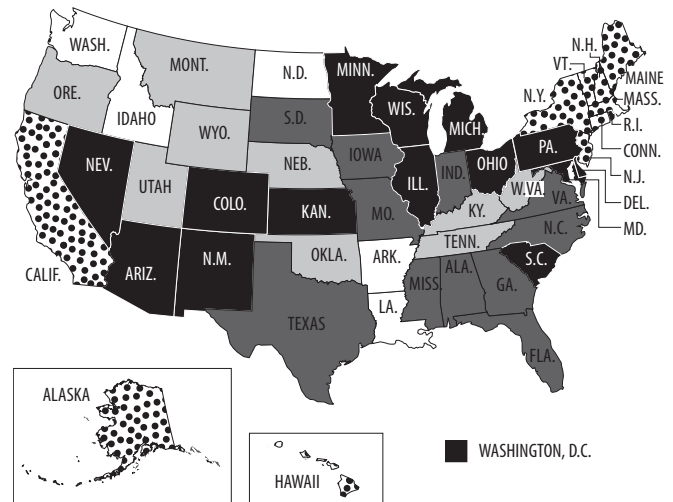

Data: Energy Information Administration



# Measuring Electricity

## Electricity Measurement

Electricity makes our lives easier, but it can seem like a mysterious force. Measuring electricity is confusing because we cannot see it. We are familiar with terms such as watt, volt, and amp, but we may not have a clear understanding of these terms. We buy a 60-watt light bulb, a tool that needs 120 volts, or a vacuum cleaner that uses 8.8 amps, and we don't think about what those units mean.

Using the flow of water as an analogy can make electricity easier to understand. The flow of electrons in a circuit is similar to water flowing through a hose. If you could look into a hose at a given point, you would see a certain amount of water passing that point each second.

The amount of water depends on how much pressure is being applied—how hard the water is being pushed. It also depends on the diameter of the hose. The harder the pressure and the larger the diameter of the hose, the more water passes each second. The flow of electrons through a wire depends on the electrical pressure pushing the electrons and on the cross-sectional area of the wire.

## Voltage

The pressure that pushes electrons in a circuit is called **voltage (V)**. Using the water analogy, if a tank of water were suspended one meter above the ground with a 1-cm diameter pipe coming out of the bottom, the water pressure would be similar to the force of a shower. If the same water tank were suspended 10 meters above the ground, the force of the water would be much greater, possibly enough to hurt you.

Voltage is a measure of the pressure applied to electrons to make them move. It is a measure of the strength of the current in a circuit and is measured in **volts (V)**. Just as the 10-meter high tank applies greater pressure than the 1-meter high tank, a 10-volt power supply (such as a battery) would apply greater pressure than a 1-volt power supply.

AA batteries are 1.5 volts; they apply a small amount of voltage or pressure for lighting small flashlight bulbs. A car usually has a 12-volt battery—it applies more voltage to push current through circuits to operate the radio or defroster.

The standard voltage of wall outlets is 120 volts—a dangerous amount of voltage. An electric clothes dryer is usually wired at 240 volts—a very dangerous voltage.

## Current

The flow of electrons can be compared to the flow of water. The water current is the number of molecules flowing past a fixed point; **electric current (I)** is the number of electrons flowing past a fixed point. Electric current is defined as electrons flowing between

## Voltage

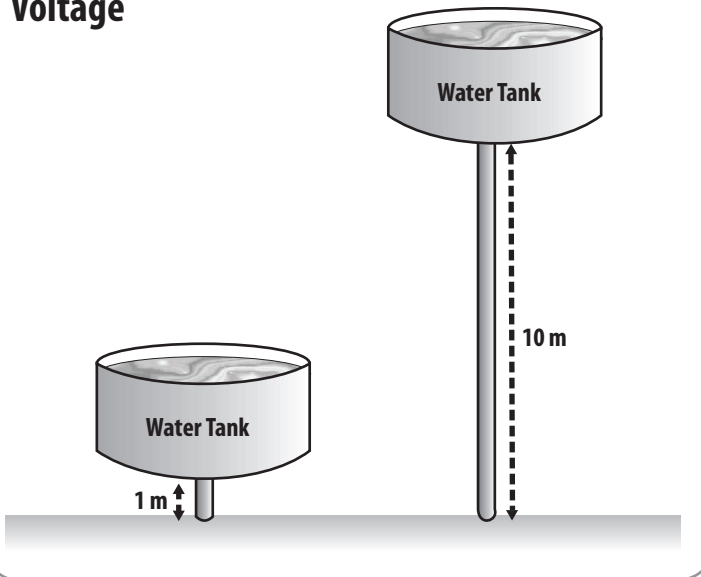

## Current

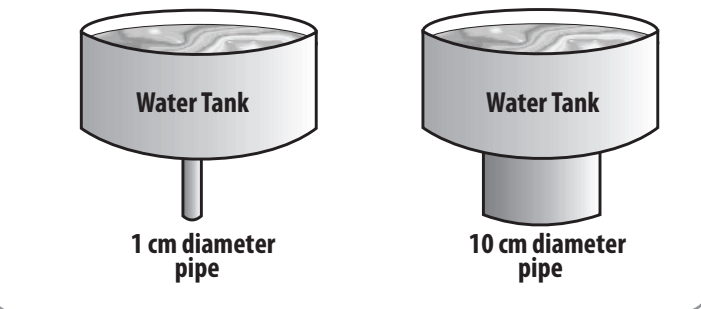

two points having a difference in voltage. Current is measured in **amperes** or **amps (A)**. One ampere is  $6.25 \times 10^{18}$  electrons per second passing through a circuit.

With water, as the diameter of the pipe increases, so does the amount of water that can flow through it. With electricity, conducting wires take the place of the pipe. As the cross-sectional area of the wire increases, so does the amount of electric current (number of electrons) that can flow through it.



# Measuring Electricity

## Resistance

**Resistance (R)** is a property that slows the flow of electrons. Using the water analogy, resistance is anything that slows water flow, a smaller pipe or fins on the inside of a pipe. In electrical terms, the resistance of a conducting wire depends on the metal the wire is made of and its diameter. Copper, aluminum, and silver—metals used in conducting wires—have different resistance.

Resistance is measured in units called **ohms (Ω)**. There are devices called resistors, with set resistances, that can be placed in circuits to reduce or control the current flow. Any device placed in a circuit to do work is called a **load**. The light bulb in a flashlight is a load. A television plugged into a wall outlet is also a load. Every load has resistance.

## Ohm's Law

George Ohm, a German physicist, discovered that in many materials, especially metals, the current that flows through a material is proportional to the voltage. In the substances he tested, he found that if he doubled the voltage, the current also doubled. If he reduced the voltage by half, the current dropped by half. The resistance of the material remained the same.

This relationship is called **Ohm's Law**, and can be written in three simple formulas. If you know any two of the measurements, you can calculate the third, using the formulas to the right.

## Electric Power

**Power (P)** is a measure of the rate of doing work or the rate at which energy is converted. Electric power is the rate at which electricity is produced or consumed. Using the water analogy, electric power is the combination of the water pressure (voltage) and the rate of flow (current) that results in the ability to do work.

A large pipe carries more water (current) than a small pipe. Water at a height of 10 meters has much greater force (voltage) than at a height of one meter. The power of water flowing through a 1-centimeter pipe from a height of one meter is much less than water through a 10-centimeter pipe from 10 meters.

**Electric power** is defined as the amount of electric current flowing due to an applied voltage. It is the amount of electricity required to start or operate a load for one second. Electric power is measured in **watts (W)**.

### ELECTRIC POWER FORMULA

- **Power = voltage x current**  
 $P = V \times I$       or       $W = V \times A$

## Resistance

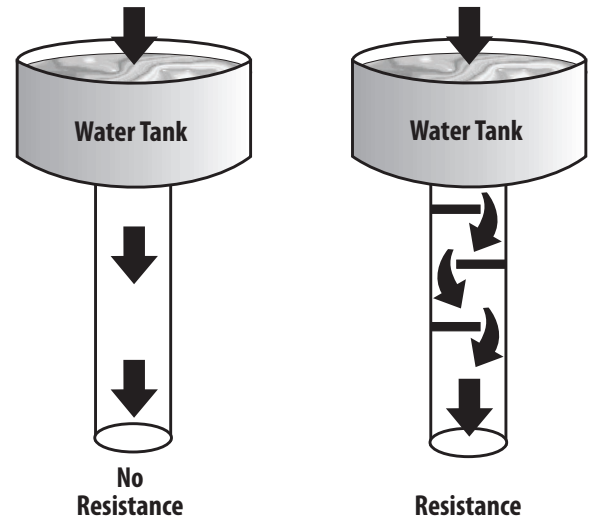

### OHM'S LAW

- **Voltage = current x resistance**  
 $V = I \times R$       or       $V = A \times \Omega$
- **Current = voltage / resistance**  
 $I = V / R$       or       $A = V / \Omega$
- **Resistance = voltage / current**  
 $R = V / I$       or       $\Omega = V / A$

## Electric Power

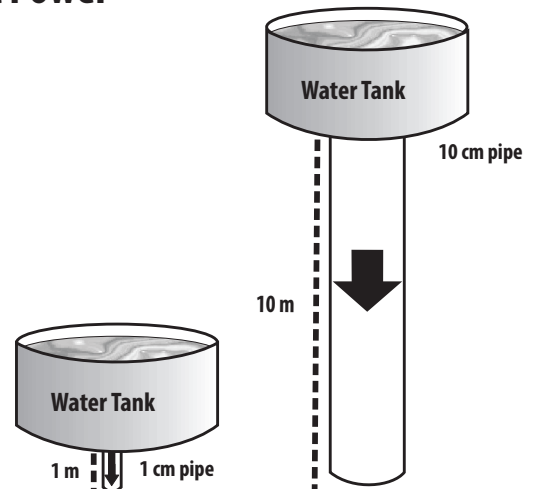



## Electrical Energy

**Electrical energy** introduces the concept of time to electric power. In the water analogy, it would be the amount of water falling through the pipe over a period of time, such as an hour. When we talk about using power over time, we are talking about using energy. Using our water example, we could look at how much work could be done by the water in the time that it takes for the tank to empty.

The electrical energy that an appliance or device consumes can be determined only if you know how long (time) it consumes electric power at a specific rate (power). To find the amount of energy consumed, you multiply the rate of energy consumption (measured in watts) by the amount of time (measured in hours) that it is being consumed. Electrical energy is measured in **watt-hours (Wh)**.

▪ **Energy (E) = Power (P) x Time (t)**

$$E = P \times t \quad \text{or} \quad E = W \times h = Wh$$

Another way to think about power and energy is with an analogy to traveling. If a person travels in a car at a rate of 40 miles per hour (mph), to find the total distance traveled, you would multiply the rate of travel by the amount of time you traveled at that rate.

If a car travels for 1 hour at 40 miles per hour, it would travel 40 miles.

$$\text{Distance} = 40 \text{ mph} \times 1 \text{ hour} = 40 \text{ miles}$$

If a car travels for 3 hours at 40 miles per hour, it would travel 120 miles.

$$\text{Distance} = 40 \text{ mph} \times 3 \text{ hours} = 120 \text{ miles}$$

The distance traveled represents the work done by the car. When we look at power, we are talking about the rate that electrical energy is being produced or consumed. Energy is analogous to the distance traveled or the work done by the car.

A person wouldn't say he took a 40-mile per hour trip because that is the rate. The person would say he took a 40-mile trip or a 120-mile trip. We would describe the trip in terms of distance traveled, not rate traveled. The distance represents the amount of work done.

The same applies with electric power. You would not say you used 100 watts of light energy to read your book, because a watt represents the rate you use energy, not the total energy used. The amount of energy used would be calculated by multiplying the rate by the amount of time you read. If you read for five hours with a 100-W bulb, for example, you would use the following formula:

▪ **Energy = Power x Time**

$$E = P \times t$$

$$\text{Energy} = 100 \text{ W} \times 5 \text{ hours} = 500 \text{ Wh}$$

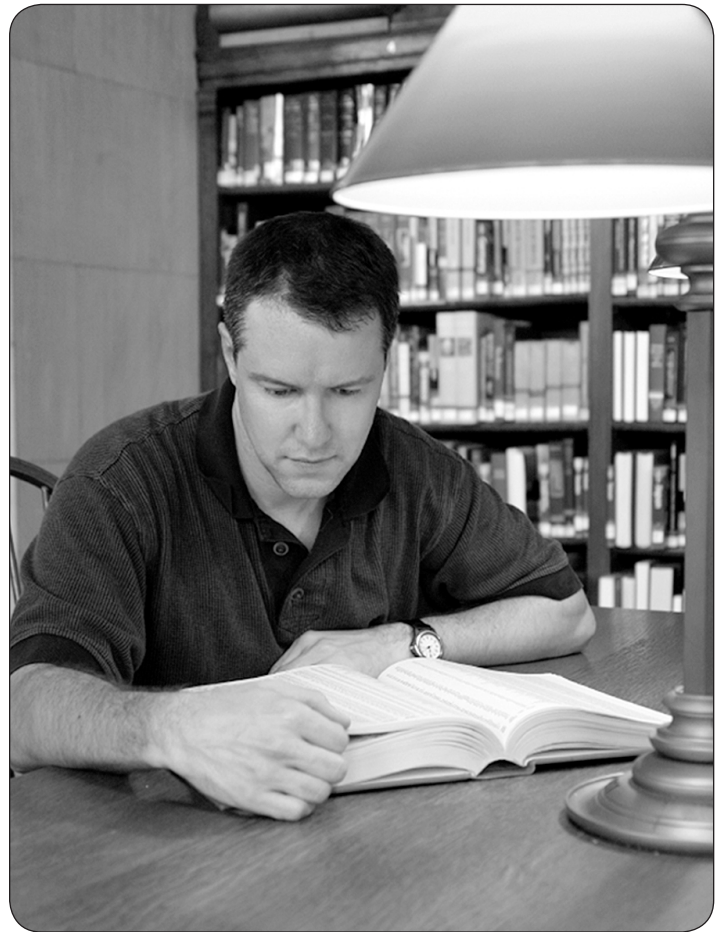

One watt-hour is a very small amount of electrical energy. Usually, we measure electric power in larger units called **kilowatt-hours (kWh)** or 1,000 watt-hours (kilo = thousand). A kilowatt-hour is the unit that utilities use when billing most customers. The average cost of a kilowatt-hour of electricity for residential customers is about 12.7 cents.

To calculate the cost of reading with a 100-W bulb for 5 hours, you would change the watt-hours into kilowatt-hours, then multiply the kilowatt-hours used by the cost per kilowatt-hour, as shown below:

$$500 \text{ Wh} \times \frac{1 \text{ kW}}{1,000 \text{ W}} = 0.5 \text{ kWh}$$

$$0.5 \text{ kWh} \times \$0.127/\text{kWh} = \$0.064$$

It would cost about six cents to read for five hours using a 100-W bulb.



# History of Electricity

## Starting with Ben

Many people think Benjamin Franklin discovered electricity with his famous kite-flying experiments in 1752. Franklin is famous for tying a key to a kite string during a thunderstorm, proving that static electricity and lightning were indeed, the same thing. However, that isn't the whole story of electricity. Electricity was not "discovered" all at once. At first, electricity was associated with light. People wanted a cheap and safe way to light their homes, and scientists thought electricity might be a way.

## A Different Kind of Power: The Battery

Learning how to produce and use electricity was not easy. For a long time there was no dependable source of electricity for experiments. Finally, in 1800, Alessandro Volta, an Italian scientist, made a great discovery. He soaked paper in salt water, placed zinc and copper on opposite sides of the paper, and watched the chemical reaction produce an electric current. Volta had created the first electric cell.

By connecting many of these cells together, Volta was able to "string a current" and create a **battery**. It is in honor of Volta that we rate batteries in **volts**. Finally, a safe and dependable source of electricity was available, making it easy for scientists to study electricity.

## A Current Began

An English scientist, Michael Faraday, was the first one to realize that an electric current could be produced by passing a magnet through a copper wire. It was an amazing discovery. Almost all the electricity we use today is made with magnets and coils of copper wire in giant power plants.

Both the electric generator and electric motor are based on this principle. A **generator** converts motion energy into electricity. A **motor** converts electrical energy into **motion energy**.

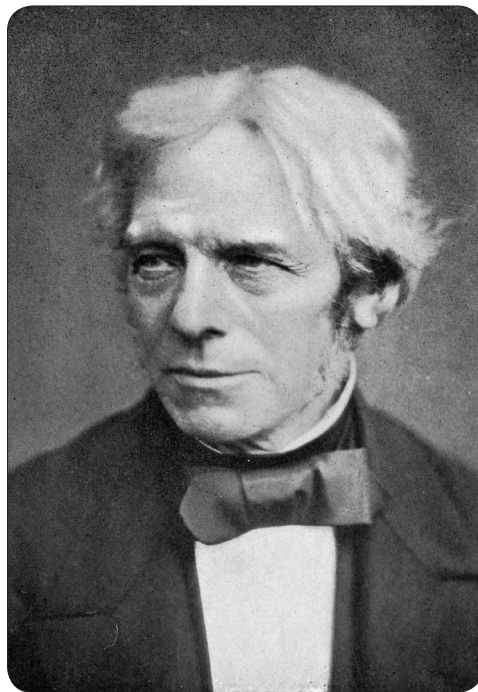

Michael Faraday

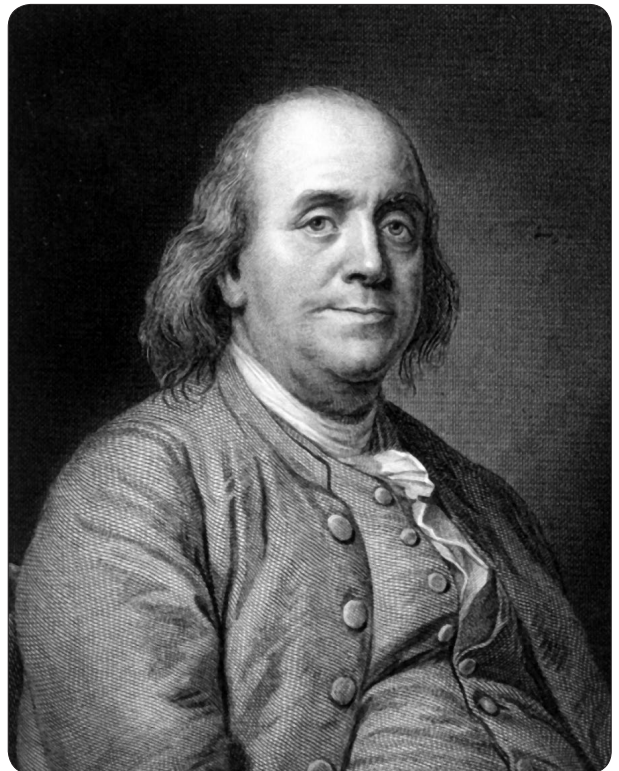

Image courtesy of NOAA Photo Library

Benjamin Franklin

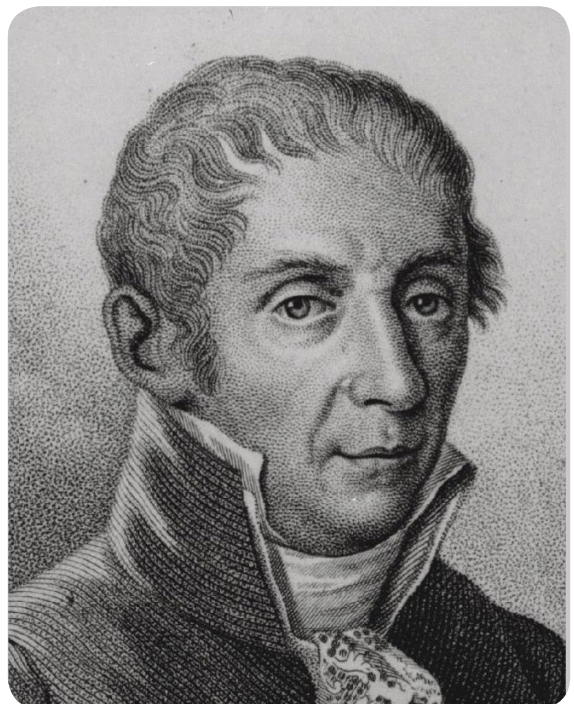

Image courtesy of Teylers Museum

Alessandro Volta



## Mr. Edison and His Light

In 1879, Thomas Edison focused on inventing a practical light bulb, one that would last a long time before burning out. The problem was finding a strong material for the **filament**, the small wire inside the bulb that conducts electricity. Finally, Edison used ordinary cotton thread that had been soaked in carbon. This filament didn't burn at all—it became **incandescent**; that is, it glowed.

The next challenge was developing an electrical system that could provide people with a practical source of energy to power these new lights. Edison wanted a way to make electricity both practical and inexpensive. He designed and built the first electric power plant that was able to produce electricity and carry it to people's homes.

Edison's Pearl Street Power Station started up its generator on September 4, 1882, in New York City. About 85 customers in lower Manhattan received enough power to light 5,000 lamps. His customers paid a lot for their electricity, though. In today's dollars, the electricity cost \$5.00 per kilowatt-hour! Today, electricity costs about 12.7 cents per kilowatt-hour for residential customers, about 11 cents for commercial, and about 7 cents per kilowatt-hour for industry.

## The Question: AC or DC?

The turning point of the electric age came a few years later with the development of **AC (alternating current)** power systems. Croatian scientist, Nikola Tesla came to the United States to work with Thomas Edison. After a falling out, Tesla discovered the rotating magnetic field and created the alternating current electrical system that is used very widely today. Tesla teamed up with engineer and business man George Westinghouse to patent the AC system and provide the nation with power that could travel long distances – a direct competition with Thomas Edison's DC system. Tesla later went on to form the Tesla Electric Company, invent the Tesla Coil, which is still used in science labs and in radio technology today, and design the system used to generate electricity at Niagara Falls.

Now using AC, power plants could transport electricity much farther than before. While Edison's **DC (direct current)** plant could only transport electricity within one square mile of his Pearl Street Power Station, the Niagara Falls plant was able to transport electricity over 200 miles!

Electricity didn't have an easy beginning. While many people were thrilled with all the new inventions, some people were afraid of electricity and wary of bringing it into their homes. They were afraid to let their children near this strange new power source. Many social critics of the day saw electricity as an end to a simpler, less hectic way of life. Poets commented that electric lights were less romantic than gaslights. Perhaps they were right, but the new electric age could not be dimmed.

In 1920, about two percent of U.S. energy was used to make electricity. In 2015, with the increasing use of technologies powered by electricity, it was almost 40 percent.

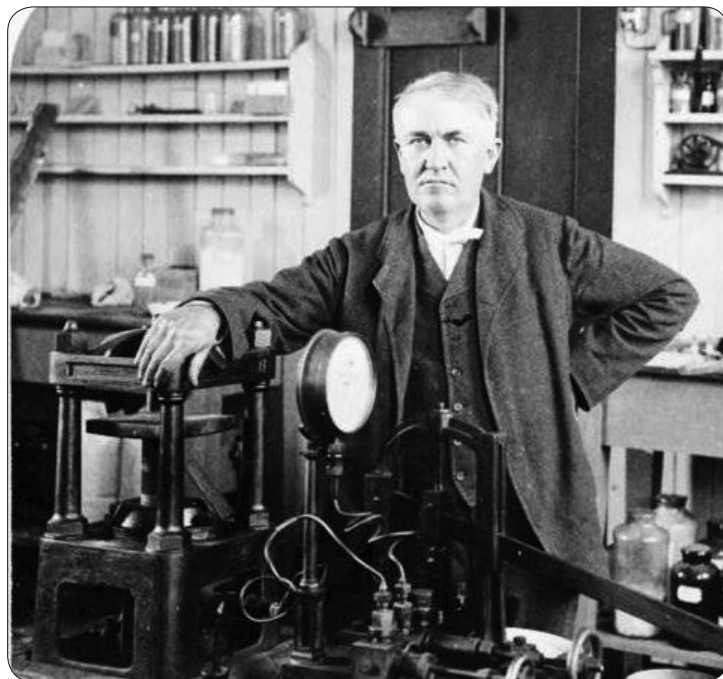

Image courtesy of U.S. Library of Congress

Thomas Edison in his lab in 1901.

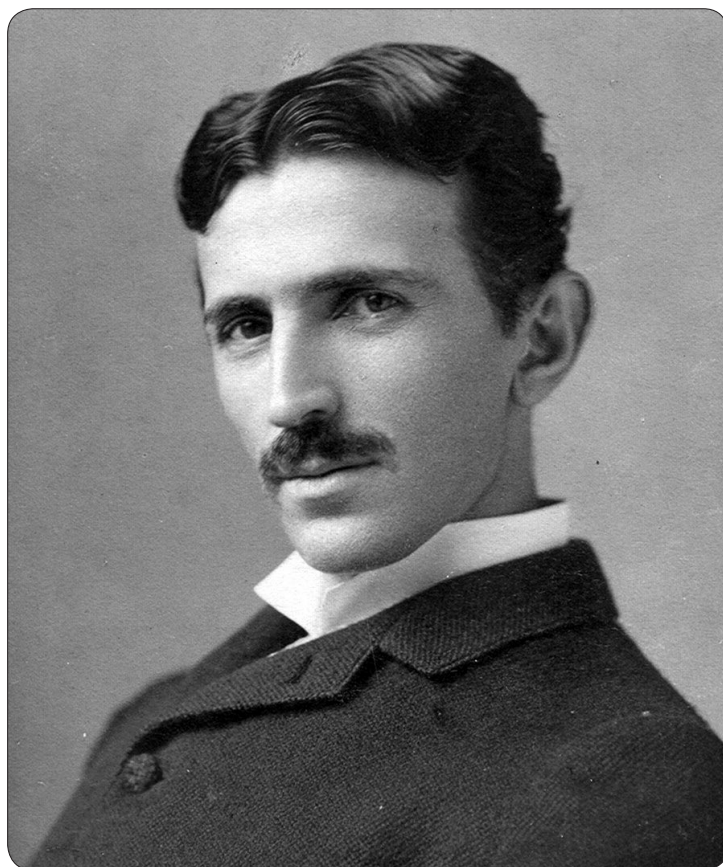

Photo by Napoleon Sarony

Nikola Tesla



# Facts of Light

## Facts of Light

Ten years ago, we used a lot of energy in the form of electricity to make light to be able to see. Thirty percent of the electricity schools used was for lighting, and homes used about 14 percent of their electricity consumption for lighting. That's because homes, schools, and other commercial buildings used a lot of incandescent lighting. These inefficient bulbs were perfected by Thomas Edison in 1879 and didn't change much for the next 125 or more years! These bulbs were surprisingly inefficient, converting up to 90 percent of the electricity they consumed into heat.

The Energy Independence and Security Act of 2007 changed the standards for the efficiency of light bulbs used most often. As of 2014, most general use bulbs must be 30 percent more efficient than traditional, inefficient incandescent bulbs. What do the new standards mean for consumers? The purpose of the new efficiency standards is to give people the same amount of light by using less energy. Most incandescent light bulbs have since been phased out and are no longer available for sale. This has resulted in significant energy savings for homes and schools. Newer, efficient lighting now accounts for eleven percent of the electricity used in schools, and only five percent used in homes.

There are several lighting choices on the market that meet the new efficiency standards. Energy-saving incandescent, or halogen, bulbs

are different than traditional, inefficient incandescent bulbs because they have a capsule around the filament (the wire inside the bulb) filled with halogen gas. This allows the bulbs to last three times longer and use 25 percent less energy.

Compact fluorescent light bulbs (CFLs) provide the same amount of light as incandescent bulbs, but use up to 75 percent less energy and last ten times longer. CFLs produce very little heat. Using CFLs can help cut lighting costs and reduce environmental impacts. Today's CFL bulbs fit almost any socket, produce a warm glow and, unlike earlier models, no longer flicker and dim. CFLs have a small amount of mercury inside and should always be recycled rather than thrown away. Many retailers recycle CFLs for free.

Light emitting diodes, better known as LEDs, are gaining in popularity. Once used mainly for exit signs and power on/off indicators, improved technology and lower prices are enabling LEDs to be used in place of incandescents and CFLs. LEDs are one of the most energy-efficient lighting choices available today. LEDs use 75 percent less energy than traditional incandescents, and have an average lifespan of at least 25,000 hours. The cost of LEDs has dropped in the last five years and may continue to drop. They use even less energy than CFLs, save more electricity, and produce fewer carbon dioxide emissions. The U.S. Department of Energy estimates that widespread adoption of LED lighting by 2027 would reduce lighting electricity demand by 33 percent. This would avoid construction of 40 new power plants.

## Cost of 25,000 Hours of Light

All bulbs provide about 850 lumens of light.



COST OF BULB	INCANDESCENT BULB	HALOGEN	COMPACT FLUORESCENT (CFL)	LIGHT EMITTING DIODE (LED)
Life of bulb (how long it will light)	1,000 hours	3,000 hours	10,000 hours	25,000 hours
Number of bulbs to get 25,000 hours	25 bulbs	8.3 bulbs	2.5 bulbs	1 bulb
<b>x</b> Price per bulb	\$0.50	\$3.00	\$3.00	\$4.00
<b>= Cost of bulbs for 25,000 hours of light</b>	<b>\$12.50</b>	<b>\$24.90</b>	<b>\$7.50</b>	<b>\$4.00</b>

COST OF ELECTRICITY	INCANDESCENT BULB	HALOGEN	COMPACT FLUORESCENT (CFL)	LIGHT EMITTING DIODE (LED)
Total Hours	25,000 hours	25,000 hours	25,000 hours	25,000 hours
<b>x</b> Wattage	60 watts = 0.060 kW	43 watts = 0.043 kW	13 watts = 0.013 kW	12 watts = 0.012 kW
<b>= Total kWh consumption</b>	<b>1,500 kWh</b>	<b>1075 kWh</b>	<b>325 kWh</b>	<b>300 kWh</b>
<b>x</b> Price of electricity per kWh	\$0.127	\$0.127	\$0.127	\$0.127
<b>= Cost of Electricity</b>	<b>\$190.50</b>	<b>\$136.53</b>	<b>\$41.28</b>	<b>\$38.10</b>

LIFE CYCLE COST	INCANDESCENT BULB	HALOGEN	COMPACT FLUORESCENT (CFL)	LIGHT EMITTING DIODE (LED)
Cost of bulbs	\$12.50	\$24.90	\$7.50	\$10.00
<b>+</b> Cost of electricity	<b>\$190.50</b>	<b>\$136.53</b>	<b>\$41.28</b>	<b>\$38.10</b>
<b>= Life cycle cost</b>	<b>\$203.00</b>	<b>\$161.43</b>	<b>\$48.78</b>	<b>\$42.10</b>

ENVIRONMENTAL IMPACT	INCANDESCENT BULB	HALOGEN	COMPACT FLUORESCENT (CFL)	LIGHT EMITTING DIODE (LED)
Total kWh consumption	1500 kWh	1075 kWh	325 kWh	300 kWh
<b>x</b> Pounds (lbs) of carbon dioxide per kWh	1.5 lb/kWh	1.5 lb/kWh	1.5 lb/kWh	1.5 lb/kWh
<b>= Pounds of carbon dioxide produced</b>	<b>2,250.0 lbs carbon dioxide</b>	<b>1,612.5 lbs carbon dioxide</b>	<b>487.5 lbs carbon dioxide</b>	<b>450.0 lbs carbon dioxide</b>





# Energy Consumption

## Energy Use

Think about how you use energy every day. You wake up to an alarm clock. You take a shower with water warmed by a hot water heater. You listen to music on the radio as you dress. You catch the bus to school. That's just the energy you use before you get to school! Every day, the average American uses about as much energy as is stored in about seven gallons of gasoline. Energy use is sometimes called energy consumption.

## Who Uses Energy?

The U.S. Department of Energy divides energy users into different categories: **residential, commercial, industrial, electric power, and transportation**. These are called the sectors of the economy.

## Residential and Commercial Sectors

Any place where people live is considered a residential building. Commercial buildings include offices, stores, hospitals, restaurants, and schools. Residential and commercial buildings are often grouped together because they use energy in the same ways—for heating and cooling, lighting, heating water, and operating appliances.

Together, homes and buildings consume almost 11 percent of the energy used in the United States today. In the last 30 years, Americans have reduced the amount of energy used in their homes and commercial buildings. We still heat and cool rooms, and heat hot water. We have more home and office machines than ever. Most of the energy savings have come from improvements in technology and in the ways the equipment is manufactured.

### ■ Heating and Cooling

It takes a lot of energy to heat rooms in winter and cool them in summer. Forty-eight percent of the energy used in the average home is for heating and cooling rooms. The three fuels used most often for heating are natural gas, electricity, and heating oil. Today, more than half the nation's homes use natural gas for heating.

Most natural gas furnaces in the 1970s and 1980s were about 60 percent efficient. That means they converted 60 percent of the energy in the natural gas into usable heat. New gas furnaces are designed to be up to 98 percent efficient.

The second leading fuel for home heating is electricity. Electricity also provides almost all of the energy used for air conditioning. The efficiency of heat pumps and air conditioners has increased more than 50 percent in the last 35 years.

Heating oil is the third leading fuel used for home heating. In 1973, the average home used 1,300 gallons of oil a year. Today, that figure is about 517 gallons, a significant decrease. New oil furnaces burn oil more cleanly and operate more efficiently.

In the future, we may see more use of renewable energy sources, such as geothermal and solar energy, to heat and cool our homes and workspaces.

## U.S. Energy Consumption by Sector, 2015

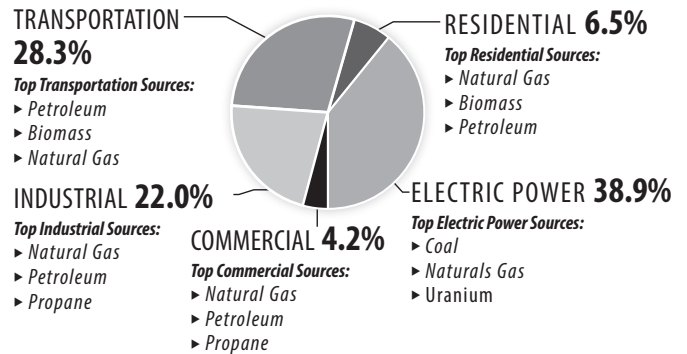

The residential, commercial, and industrial sectors use electricity. This graph depicts their energy source consumption outside of electricity.

Data: Energy Information Administration

\*Total does not equal 100% due to independent rounding.

### ■ Lighting

Homes and commercial buildings also use energy for lighting. The average home spends five percent of its utility costs on lighting. Schools, stores, and businesses use between 9 and 10 percent of their utility costs for lighting. Most commercial buildings use fluorescent lighting. It costs more to install, but it uses a lot less energy to produce the same amount of light.

Many homes still use the type of light bulb invented by Thomas Edison over 100 years ago. These **incandescent bulbs** are not very efficient. Only about 10 percent of the electricity they consume is converted into light. The other 90 percent is converted to heat.

Due to the Energy Independence and Security Act of 2007, most traditional, inefficient incandescent light bulbs have been phased out and are no longer for sale. Consumers can choose from several more efficient bulb options as replacements. Energy-saving incandescent, or **halogen**, bulbs are more expensive than traditional incandescent, but use 25 percent less energy and last three times as long.

**Compact fluorescent light bulbs (CFLs)** can be used in light fixtures throughout homes. CFLs cost less to use because they last longer and use less energy than incandescent bulbs.

Even more efficient than CFLs, **light emitting diodes (LEDs)** are available. LEDs have become a very affordable option for lighting in homes and businesses, and use even less energy than CFLs. LEDs last 25 times longer than a traditional incandescent, are more durable than the other options available on the market, and have many technical applications.

## ■ Appliances

Over the last 100 years, **appliances** have changed the way we spend our time at home. Chores that used to take hours can now be done in minutes by using electricity instead of human energy. In 1990, Congress passed the National Appliance Energy Conservation Act, which requires appliances to meet strict energy efficiency standards. As a result of this Act, home appliances have become more energy efficient. Water heaters, refrigerators, clothes washers, and dryers all use much less energy today than they did 25 years ago.

## ■ Appliance Efficiency Ratings

When you buy an appliance, you should pay attention to the yellow **EnergyGuide label** on every appliance. This label tells you the **Energy Efficiency Ratio (EER)** of the appliance. The EER tells how much it costs to operate the appliance.

## ■ Payback Period

Whether you buy a furnace, hot water heater, refrigerator, or other home appliance, you must choose the best bargain. Since most high-efficiency systems and appliances cost more than less efficient ones, you have to know how much it will cost to operate the appliance each year and how many years you can expect to use it. The **payback period** is the amount of time you must use a system or appliance before you begin to benefit from energy savings.

For example, if you buy an efficient refrigerator that costs \$100 more, but uses \$20 less electricity each year, you would begin saving money after five years. Your payback period would be five years. Since refrigerators usually last ten years, you would save \$100 over the life of the appliance and save natural resources.

## Lighting Efficiency

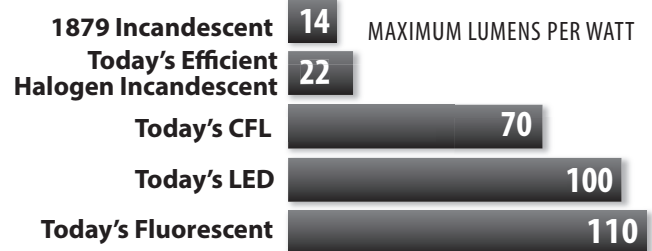

Data: Madison Gas and Electric

## ENERGYGUIDE LABEL

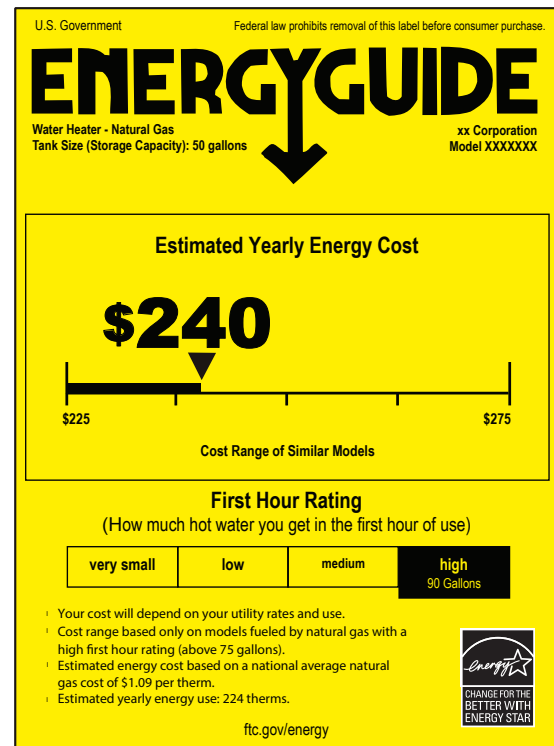

## Washing Machine Payback Period

Spending a little bit more money on an energy efficient appliance could save you several hundred dollars over the lifetime of the product. The payback period could be shorter than you think!



	WASHER 1	WASHER 2	WASHER 3
Original Cost	\$379	\$497	\$999
Estimated Annual Electricity Use	427 kWh	160 kWh	102 kWh
Price of Electricity (per kWh)	\$0.12	\$0.12	\$0.12
Operating Cost per Year	\$51.24	\$19.20	\$12.24

Data: NEED analysis of washing machine EnergyGuide labels

## COST OVER THE LIFETIME OF THE MACHINE

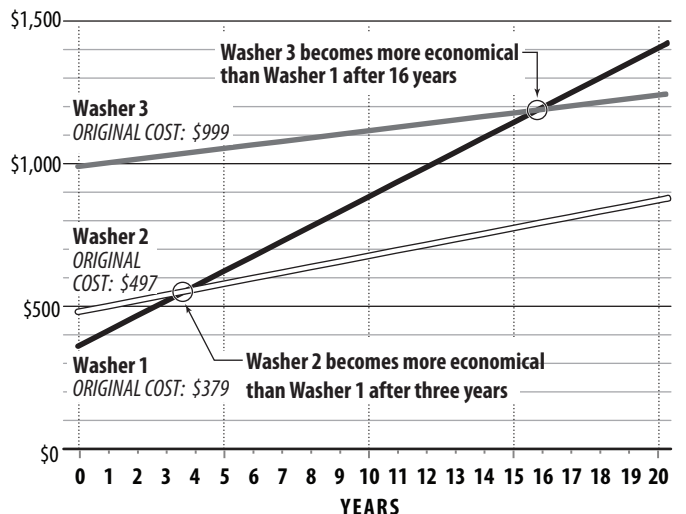

## Industrial Sector

The United States is a highly industrialized country. We use a lot of energy. Today, the industrial sector uses 22.0 percent of the nation's energy. Every industry uses energy, but six energy-intensive industries use most of the energy consumed by the industrial sector. However, advanced technologies allow industries to do more with less energy.

### ▪ Petroleum Refining

The United States uses more petroleum than any other energy source. Petroleum provides the U.S. with about 38.8 percent of the energy we use each year. Petroleum can't be used as it comes out of the ground. It must be refined before it can be used.

Oil refineries use a lot of energy to convert crude oil into gasoline, diesel fuel, aviation fuel, heating oil, chemicals, and other products. About a quarter of the energy used by the industrial sector is for refining petroleum. Refineries today use about 30 percent less energy than they did in the 1970s, but rising fuel costs provide a challenge in maintaining reductions.

### ▪ Steel Manufacturing

The steel industry uses energy to turn iron ore and scrap metal into steel. Hundreds of the products we use every day are made of steel. It is a very hard, durable metal and it must be heated to very high temperatures to manufacture it. Producing those high temperatures takes a lot of energy. The cost of energy in the steel industry is 15 percent of the total cost of making the steel. Most of this energy comes from coal and natural gas, or electricity generated from those sources.

Since 1990, the steel industry has reduced its energy consumption by 30 percent per ton of steel. New technology has made steel stronger so that less steel is needed for many uses. For example, the Willis Tower, formerly the Sears Tower, in Chicago could be built today using 35 percent less steel.

The use of recycled steel also saves energy. It requires 75 percent less energy to recycle steel than to make it from iron ore. Today, two-thirds of new steel is made from recycled scrap, making steel the nation's leading recycled product.

### ▪ Aluminum Manufacturing

Aluminum is a very light-weight, versatile metal. We use aluminum to make soft drink cans, building materials, car parts, and many other products.

It takes huge amounts of electricity to make aluminum from **bauxite**, or aluminum ore. The cost for this energy is about one-third the total cost of manufacturing aluminum. Today, it takes 20 percent less energy to produce a pound of aluminum than it did 20 years ago. Using recycled aluminum requires about 95 percent less energy than converting bauxite into metal.

## U.S. Industrial Energy Consumption by Source, 2015

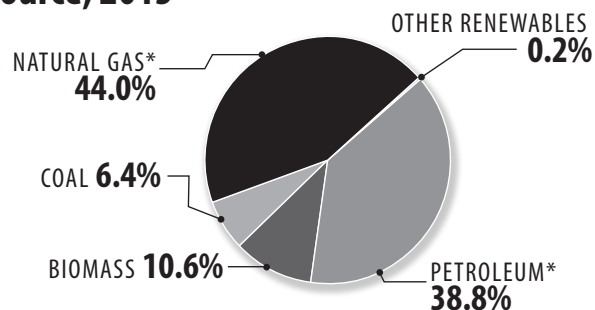

Data: Energy Information Administration

\*Propane consumed by industry is included in petroleum and natural gas consumption figures.

### PETROLEUM REFINERY



Image courtesy of BP

### STEEL PRODUCTION





## ■ Paper Manufacturing

The United States uses enormous amounts of paper every day—newspapers, books, bags, and boxes are all made of paper. Energy is used in every step of paper making. Energy is used to chop, grind, and cook the wood into pulp. More energy is used to roll and dry the pulp into paper.

The paper and pulp industry uses 30 percent less fossil fuels today than in the past, mainly because of better technology and increased use of wood waste to generate electricity on-site. Many industries have lowered energy use by using recycled materials. In the paper and pulp industry, it is not always cheaper to use recycled paper because it costs money to collect, sort, and process the waste paper.

Recycling has other benefits, though. It reduces the amount of paper in landfills and means fewer trees must be cut.

## ■ Chemical Manufacturing

Chemicals are an important part of our lives. We use chemicals in our medicines, cleaning products, fertilizers and plastics, as well as in many of our foods. The U.S. has the world's largest chemical industry. Chemical manufacturing uses almost one-quarter of the energy consumed by the industrial sector.

The chemical industry uses energy in two ways. It uses coal, oil, and natural gas to power the machinery to make the chemicals. It also uses petroleum, propane, and natural gas as major sources of **hydrocarbons** from which the chemicals are made.

New technology has increased energy efficiency in the chemical industry by more than 50 percent in the last 35 years.

## ■ Cement Manufacturing

Some people think the United States is becoming a nation of concrete. New roads and buildings are being built everywhere, every day. We use lots of concrete.

Concrete is made from cement, water, and crushed stone. A lot of energy is used in making cement. The process requires extremely high temperatures—up to 1,800 degrees Celsius (3,400°F).

Cement plants have reduced their energy consumption by more than one-third using innovative waste-to-energy programs. Many of the cement plants in the U.S. use waste fuels to meet between 20 and 70 percent of their energy needs. These wastes, such as printing inks, dry cleaning fluids, and used tires, have high energy content. For example, the energy content of one pound of tires is greater than one pound of coal. This industry is using energy that would otherwise be wasted in a landfill.

## Reduction in Manufacturing Energy Use, 2002 - 2010

With advancements in technology and increased efficiency and conservation measures, the total U.S. manufacturing energy consumption decreased by 17% from 2002-2010.

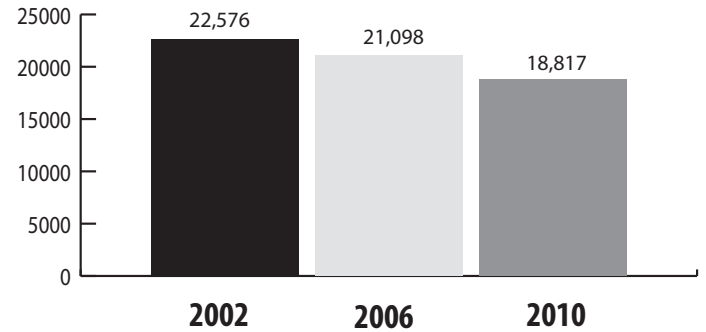

Data: Energy Information Administration

## PAPER RECYCLING



Image courtesy of National Renewable Energy Laboratory



## Transportation Sector

The United States is a big country. The transportation sector uses more than 28 percent of the energy supply to move people and goods from one place to another.

### ■ The Automobile

Americans love automobiles. We love to drive them. We don't want anyone telling us what kind of car to buy or how much to drive it. Forty years ago, most Americans drove big cars that used a lot of gas. The gas shortages of the 1970s didn't change Americans' driving habits much. What did change was the way automobiles were built. Automakers began making cars smaller and lighter. They built smaller and more efficient engines.

One reason for the changes was that the government passed laws requiring automobiles to get better gas mileage. With new technologies, cars now travel more miles on each gallon of gas. Today, new passenger cars get an average of 35 miles per gallon. If automakers hadn't made these changes, we would be using 30 percent more fuel than we do today.

In 1973, there were 125 million vehicles on the road. Today, there are more than 240 million vehicles. There are more cars being driven more miles than ever before. Around fifty percent of the passenger vehicles sold in 2013 were sport utility vehicles and light trucks. With the recent fluctuations in fuel prices, however, demand for these big vehicles has dropped somewhat, while demand for hybrids and other fuel efficient vehicles has increased.

### ■ Commercial Transportation

Passenger cars and light trucks consume about two-thirds of the fuel we use for transportation. Commercial vehicles consume the rest. These vehicles—trains, trucks, buses, and planes—carry people and products all across this vast country. Commercial vehicles have also become more fuel efficient in the last 40 years.

■ **Trucks** use more fuel than any other commercial vehicle. Almost all products are, at some point, transported by truck. Trucks are big and don't get good gas mileage. They usually have diesel engines and can travel farther on a gallon of diesel fuel than they could on a gallon of gasoline.

■ **Trains** carry most of the freight between cities. In the last 30 years, trains have improved their fuel efficiency by 55 percent. Trains are lighter and stronger and new locomotives are more efficient.

■ **Airplanes** move people and products all over the country. In 2015, more than 800 million passengers flew on planes. Airlines are twice as efficient today as they were 30 years ago. Fuel is one of the biggest operating costs for airlines. Making planes more energy efficient is very important to airlines.

■ **Mass Transit** is public transportation for moving people on buses, trains, light rail, and subways. In 1970, nine percent of workers who commuted to work used public transit systems. Today, only five percent travel by mass transit. Why is this? One reason is that Americans love their cars. Another is that people have moved from cities to suburbs and many businesses have followed. Most mass transit systems were designed to move people around cities or from suburbs to cities. Very few systems move people from suburb to suburb.

Most people worry about air pollution from auto exhaust. They also worry about traffic congestion. Congress has passed legislation supporting public transit. If public transit is convenient and the cost is reasonable, people may leave their cars at home.

### Average Fuel Economy of New Passenger Cars

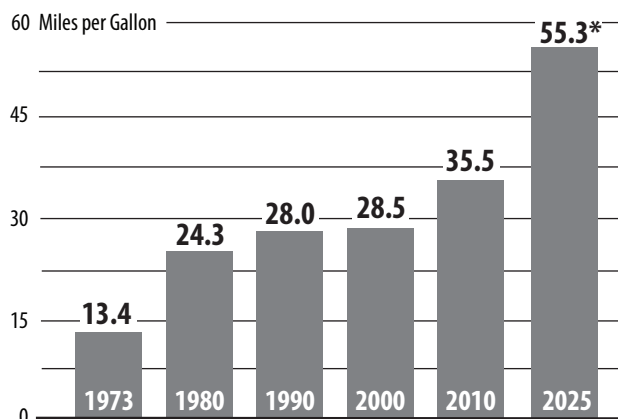

\*By 2025 new model cars and light trucks may have to meet a 55.3 mpg fuel economy standard.

Data: U.S. Department of Energy

### TRAFFIC CONGESTION





# Energy Efficiency

## Energy Consumption

The United States uses a lot of energy—over two million dollars worth each minute, 24 hours a day, every day of the year. With less than five percent of the world’s population, we consume about 17.94 percent of its energy. People in Europe and Japan also use a large amount of energy. The average American consumes 4.0 times more energy than the world average.

## Efficiency and Conservation

Energy is more than numbers on a utility bill; it is the foundation of everything we do. All of us use energy every day—for transportation, cooking, heating and cooling rooms, manufacturing, lighting, and entertainment. We rely on energy to make our lives comfortable, productive, and enjoyable. To maintain our quality of life, we must use our energy resources wisely.

The choices we make about how we use energy—turning machines off when we’re not using them or choosing to buy energy efficient appliances—impact our environment and our lives. There are many things we can do to use less energy and use it more wisely. These things involve energy conservation and energy efficiency. Many people think these terms mean the same thing, but they are different.

**Energy conservation** is any behavior that results in the use of less energy. **Energy efficiency** is the use of technology that requires less energy to perform the same function. A **compact fluorescent light bulb** that uses less energy than an **incandescent light bulb** to produce the same amount of light is an example of energy efficiency. The decision to replace an incandescent light bulb with a compact fluorescent is an example of energy conservation.

As consumers, our energy choices and actions can result in reductions in the amount of energy used in each sector of the economy—residential, commercial, industrial, and transportation.

## Residential/Commercial

Households use just over one-fifth of the total energy consumed in the United States each year. The typical U.S. family spends more than \$2,000 a year on utility bills.

Much of this energy is not put to use. Heat pours out of homes through drafty doors and windows, as well as through ceilings and walls that aren’t insulated. Some appliances use energy 24 hours a day, even when they are turned off. Energy efficient improvements can make a home more comfortable and save money. Many utility companies provide energy audits to identify areas where homes are wasting energy. These audits may be free or low cost.

## Selected Countries and Energy Consumption, 2014

Country	Population (millions)	Total Primary Energy Consumption (Qbtu)	Energy per capita (MBtu/person)
China	1,364.27	121.09	88.76
India	1,295.29	32.73	25.27
United States	319.17	87.95	275.54
Indonesia	254.46	8.95	35.17
Brazil	206.08	12.03	58.39
Pakistan	184.04	3.57	19.38
Nigeria	177.48	5.35	30.12
Russia	143.82	28.21	196.15
Japan	127.12	17.53	137.90
Mexico	119.17	7.46	62.60
Germany	80.98	12.13	149.81
Iran	78.14	9.41	120.40
Thailand	67.73	5.35	78.96
France	66.17	9.63	145.52
United Kingdom	64.60	7.12	110.22
South Africa	54.00	5.83	108.04
South Korea	50.42	10.65	211.25
Canada	35.54	11.11	312.51
Saudi Arabia	30.89	8.47	274.29
Australia	23.64	4.97	210.23
Netherlands	16.86	2.89	171.70
Chile	17.84	1.43	80.30
Honduras	7.96	0.21	26.67
Haiti	10.57	0.16	15.58
Libya	6.26	0.71	113.28
Iraq	34.81	1.96	56.41
Dominican Republic	10.41	0.30	29.12
Kuwait	3.75	1.34	358.52

\*2015 Global Data not yet available for all nations.

Data: Energy Information Administration, The World Bank

### ■ Heating and Cooling

Heating and cooling systems use more energy than any other systems in our homes. Typically, about half of the energy of an average family’s utility bills is used to keep homes at a comfortable temperature. You can save energy and money by installing **insulation**, maintaining and upgrading the equipment, and practicing energy efficient behaviors. A seven to 10 degree adjustment to your thermostat setting (lower in winter, higher in summer) for just eight hours per day can lower heating and cooling bills by 10 percent. Programmable **thermostats** can automatically control temperature for time of day and season.

## ■ Insulation and Weatherization

You can reduce heating and cooling needs by investing in insulation and weatherization products. Warm air leaking into your home in summer and out of your home in winter can waste a lot of energy.

Insulation wraps your house in a nice warm blanket, but air can still leak in or out through small cracks. Often the effect of small leaks is the same as keeping a door wide open. One of the easiest money-saving measures you can do is caulk, seal, and weather-strip all the cracks to the outside. You can save 10 percent or more on your energy bill by stopping the air leaks in your home.

## ■ Doors and Windows

About one-quarter of a typical home's heat loss occurs through the doors and windows. Energy efficient doors are insulated and seal tightly to prevent air from leaking through or around them. If your doors are in good shape and you don't want to replace them, make sure they seal tightly and have door sweeps at the bottom to prevent air leaks. Installing insulated storm doors provides an additional barrier to leaking air. Most homes have many more windows than doors. Replacing older windows with new energy efficient ones can reduce air leaks and utility bills. The best windows are constructed of two or more pieces of glass separated by a gas that does not conduct heat well.

If you cannot replace older windows, there are several things you can do to make them more energy efficient. First, caulk any cracks around the windows and make sure they seal tightly. Add storm windows or sheets of clear plastic to the outside to create additional air barriers. You can also hang insulated drapes on the inside. In cold weather, open them on sunny days and close them at night. In hot weather, close them during the day to keep out the sun.



Windows, doors, and skylights are part of the government-backed **ENERGY STAR**® program that certifies energy efficient products. To meet ENERGY STAR® requirements, windows, doors, and skylights must meet standards tailored for the country's three broad climate regions.

## ■ Landscaping

Although it isn't possible to control the weather, landscaping can reduce its impact on home energy use. By placing trees, shrubs, and other landscaping to block the wind and provide shade, people can reduce the energy needed to keep their homes comfortable during heating and cooling seasons.

## Home Energy Usage, 2015

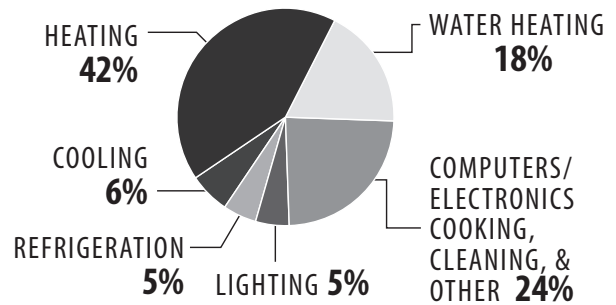

Data: U.S. Department of Energy

## ■ Electricity and Appliances

Appliances that contribute the most to a typical household's energy use are refrigerators, clothes washers, and dryers. When shopping for new appliances, you should think of two price tags. The first one is the purchase price. The second price tag is the cost of operating the appliance during its lifetime.

You'll be paying that second price tag on your utility bill every month for the next 10 to 20 years, depending on the appliance. Many energy efficient appliances cost more to buy, but save money in lower energy costs. Over the life of an appliance, an energy efficient model is always a better deal.

When you shop for new appliances, consider only those with the ENERGY STAR® label, which means they have been rated by the U.S. Environmental Protection Agency and Department of Energy as the most energy efficient appliances in their classes.

If every clothes washer purchased in the U.S. this year earned the ENERGY STAR® label, we would save 540 million kilowatt-hours of electricity, 20 billion gallons of water, and 1.4 trillion **Btus** of natural gas, resulting in energy bill savings of about \$250 million every year.

Another way to compare appliances is by using **EnergyGuide labels**. The government requires appliances to display yellow and black EnergyGuide labels. These labels do not tell you which appliances are the most efficient, but they will tell you the annual energy usage and average operating cost of each appliance so that you can compare them.

## ▪ Lighting

Starting in 2012, legislation under the Energy Independence and Security Act put restrictions on how much energy light bulbs use. Traditional, inefficient incandescent bulbs have been replaced with more efficient models.

**Halogen**, or energy-saving incandescent bulbs, are more expensive than incandescent bulbs, but use 25 percent less energy and last three times as long.

**Compact fluorescent light bulbs (CFLs)** provide the same amount of light as incandescent bulbs. CFLs can cost more to buy, but they save money in the long run because they use only one-quarter the energy of incandescent bulbs and last 10 times longer.

**Light emitting diodes (LEDs)** are even more efficient than CFL bulbs and last longer, too. While they may cost slightly more than other bulbs, savings are evident very early on after switching to LED bulbs from incandescents.

## ▪ Water Heating

Water heating is the second largest energy expense in your home. It typically accounts for about 18 percent of your utility bill. Heated water is used for showers, baths, laundry, dishwashing, and general cleaning. There are four main ways to cut your water heating bills—use less hot water, turn down the thermostat on your water heater, insulate your water heater and pipes, and buy a new, more efficient water heater.

Other ways to conserve hot water include taking showers instead of baths, taking shorter showers, fixing leaks in faucets and pipes, and using the lowest temperature settings on clothes washers.

## Transportation

Americans make up less than five percent of the world's population, yet own about 15% of its automobiles. The transportation sector of the U.S. economy accounts for 28.3 percent of total energy consumption. America is a country on the move.

The average price of gasoline in 2015 was \$2.45 per gallon. If the average vehicle is driven 11,300 miles each year, and gets an average of 23.4 **miles per gallon (mpg)**, the average driver spent over \$1,200 per year on gasoline in 2015. A person driving a smaller, more fuel-efficient car will have spent as little as \$800 per year, while a person driving a larger vehicle that is less efficient could spend \$4,000 or more each year on fuel.

The average fuel economy of new cars and light trucks increased significantly from the mid-1970s through the mid-1980s. Unfortunately, it declined from a high of about 26 miles per gallon (mpg) in 1987 to 24.5 mpg in the late 1990s due to larger vehicles, more horsepower, and increased sales of sport utility vehicles (SUVs) and trucks. In 2015, new car fuel economy rose above 36 mpg, due to demand for hybrid and fuel efficient vehicles.

When buying a vehicle, you can save a lot by choosing a fuel-efficient model. All new cars must display a mileage performance label, or Fuel Economy Label, that lists the estimated miles per gallon for both city and highway driving. Compare the fuel economy of the vehicles you are considering and make it a priority. Over the life of the vehicle, you can save thousands of dollars and reduce emissions significantly.

## Water Heater Comparison

ANNUAL ENERGY COSTS PER YEAR

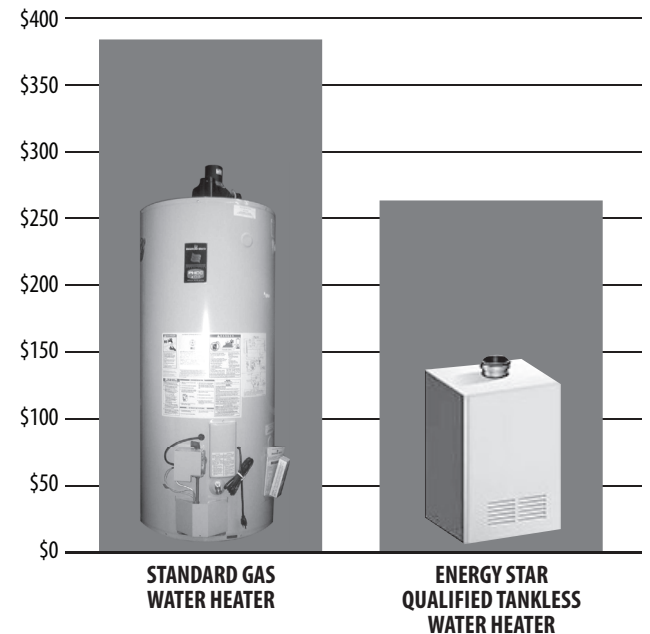

Data: ENERGY STAR

## Fuel Economy Label

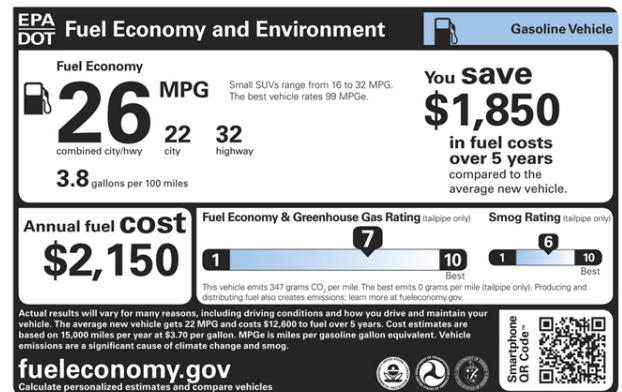

Image of label courtesy of www.fueleconomy.gov

## HYBRID PASSENGER VEHICLE

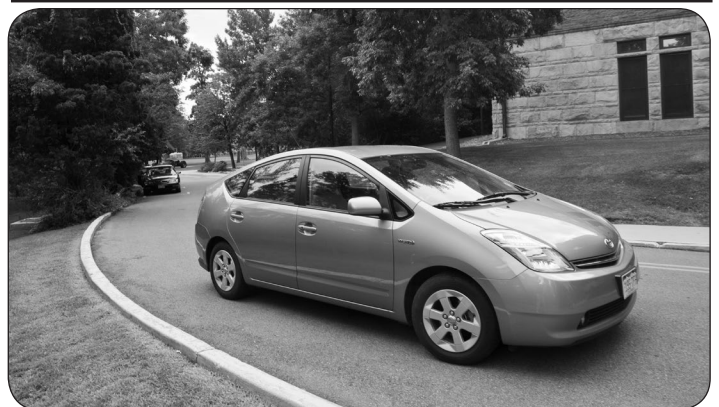

Image courtesy of NREL



## Manufacturing

Manufacturing the goods we use every day consumes an enormous amount of energy. The industrial sector of the U.S. economy consumes a little more than one-fifth of the energy used in the U.S.

In the industrial sector, the economy controls energy efficiency and conservation measures. Manufacturers know that they must keep their costs low to compete in the global economy. Since energy is one of the biggest costs in many industries, manufacturers must use energy efficient technologies and conservation measures to be successful. Their demand for energy efficient equipment drives much of the research and development of new technologies.

Individual consumers can, however, have an effect on industrial energy use through the product choices we make and what we do with packaging and products we no longer use.

### ▪ A Consumer Society

Every American produces almost 1,600 pounds of trash a year. The most effective way for consumers to help reduce the amount of energy consumed by industry is to decrease the number of unnecessary products produced and to reuse or repair items whenever possible. Purchasing only those items that are necessary, while also reusing and **recycling** products can reduce energy use in the industrial sector.

The four “Rs” of an energy-wise consumer are easy to put into practice. Reducing, reusing, repairing, and recycling help protect the environment and save money, energy, and natural resources.

### REDUCE

Buy only what you need. Purchasing fewer goods means less to throw away. It also results in fewer goods being produced and less energy being used in the manufacturing process. Buying goods with less packaging also reduces the amount of waste generated and the amount of energy used.

### REUSE

Buy products that can be used repeatedly. If you buy things that can be reused rather than disposable items that are used once and thrown away, you will save natural resources. You’ll also save the energy used to make them and reduce the amount of landfill space needed to contain the waste.

### REPAIR

Many people throw away products when they break and buy new ones. Many of these products could be easily and cheaply repaired. Always consider repairing a product before throwing it away. It saves energy, money, and natural resources.

### RECYCLE

Make it a priority to recycle all materials that you can. Using recycled material almost always consumes less energy than using new materials. Recycling reduces energy needs for mining, refining, and many other manufacturing processes.



Recycling a pound of steel can save 1.25 pounds of iron ore. Recycling aluminum cans saves 95 percent of the energy required to produce aluminum from bauxite. Recycling one ton of paper saves seven gallons of water.

## Energy Sustainability

Efficiency and conservation are key components of energy **sustainability**—the concept that every generation should meet its energy needs without compromising the energy needs of future generations. Energy sustainability focuses on long-term energy strategies and policies that ensure adequate energy to meet today’s needs, as well as tomorrow’s.

Sustainability also includes investing in research and development of advanced technologies for producing conventional energy sources, promoting the use of alternative energy sources, and encouraging sound environmental policies.



Energy sustainability focuses on long-term energy strategies and policies that ensure adequate energy to meet today’s needs, as well as tomorrow’s.



# Glossary

<b>a</b>	<b>acid rain</b>	precipitation that has a low pH, usually caused by man-made emissions that react with water molecules in the atmosphere
	<b>active solar home</b>	a solar water or space-heating system that moves heated air or water using pumps or fans
	<b>alternating current</b>	an electric current that reverses its direction at regular intervals or cycles; in the U.S. the standard is 120 reversals or 60 cycles per second; typically abbreviated as AC
	<b>ampere (A)</b>	a unit of measure for an electric current; the amount of current that flows in a circuit at an electromotive force of one volt and at a resistance of one ohm; abbreviated as amp
	<b>anemometer</b>	a device used to measure wind speed
	<b>appliance</b>	a piece of equipment, commonly powered by electricity, used to perform a particular energy-driven function; examples of common appliances are refrigerators, clothes washers and dishwashers, conventional ranges/ovens and microwave ovens, humidifiers and dehumidifiers, toasters, radios, and televisions
	<b>atmosphere</b>	a layer of gases surrounding the Earth, or any planet
	<b>atom</b>	a tiny unit of matter made up of protons and neutrons in a small, dense core, or nucleus, with a cloud of electrons surrounding the core
	<b>atomic number</b>	the number of protons within an atom of one element
<b>b</b>	<b>battery</b>	a device that stores chemical energy that can later be transformed into electrical energy
	<b>bauxite</b>	the ore that provides the principle source of aluminum
	<b>biofuels</b>	liquid fuels and blending components produced from biomass (plant) feedstock, used primarily for transportation
	<b>biogas</b>	a gas produced when organic material breaks down or decays
	<b>biomass</b>	any organic (plant or animal) material that is available on a renewable basis, including agricultural crops and agricultural wastes and residues, wood and wood wastes and residues, animal wastes, municipal wastes, and aquatic plants
	<b>British thermal unit (Btu)</b>	the amount of heat required to raise the temperature of one pound of water one degree Fahrenheit; equal to 252 calories; is abbreviated as Btu
	<b>bulk plant</b>	a filling station for propane dealers
<b>C</b>	<b>carbohydrates</b>	an energy rich organic compound made of carbon, hydrogen, and oxygen
	<b>carbon dioxide</b>	a colorless, odorless noncombustible gas with the formula $\text{CO}_2$ that is present in the atmosphere; it is formed by combustion and by respiration
	<b>chain reaction</b>	a self-sustaining nuclear reaction that takes place during fission; uranium absorbs a neutron and divides, releasing additional neutrons that are absorbed by other fissionable nuclei, releasing still more neutrons

<b>chemical energy</b>	energy stored in the chemical bonds of a substance and released during a chemical reaction such as burning wood, coal, or oil
<b>chemical reaction</b>	a reaction occurring between elements or compounds when chemical bonds are broken or formed through digestion, or combustion, for example; items formed in a chemical reaction are transformed, thus gaining new properties
<b>circuit(s)</b>	a conductor or a system of conductors through which electric current flows
<b>climate change</b>	a term used to refer to all forms of climatic inconsistency, but especially to significant change from one prevailing climatic condition to another
<b>coal</b>	a fossil fuel formed by the breakdown of plant material hundreds of millions of years ago
<b>coal bed methane</b>	natural gas that forms within a coal deposit and can be extracted from the coal bed
<b>commercial sector (of the economy)</b>	the part of the economy having to do with the buying and selling of goods and services; the commercial sector is made up of merchants, businesses, etc.
<b>compact fluorescent light bulb</b>	a light bulb consisting of a gas-filled tube and an electronic ballast; electricity flows from the ballast through the gas, causing it to give off ultraviolet light; the ultraviolet light causes a white phosphor coating inside of the tube to emit visible light; a compact fluorescent light bulb uses less energy and transforms a smaller fraction of that energy into thermal energy than a comparable incandescent bulb
<b>concentrated solar power</b>	technologies that focus the energy from the sun onto one smaller area creating high temperatures that can produce electricity
<b>conversion</b>	changing or transforming one material into another
<b>cooling tower</b>	a tower typically used to remove waste heat from fluids used in industry or generation
<b>core</b>	the innermost layer of the Earth composed of both solid and liquid contents under extreme heat and pressure
<b>crude oil</b>	see <i>petroleum</i>
<b>crust</b>	the uppermost, brittle, thin layer of the Earth that is divided into moving plates
<b>d</b> <b>dam</b>	structure or barrier built upon a waterway to retain water or prevent flooding
<b>derrick</b>	a frame tower that supports the drill equipment used to find oil and natural gas in the Earth
<b>direct current</b>	an electric current that flows in only one direction through a circuit, as from a battery; typically abbreviated as DC
<b>distribution line</b>	power lines that carry electricity at a safer voltage to consumers
<b>distribution terminal</b>	facility used by propane companies to store propane before shipping to retailers
<b>drilling rig</b>	equipment used for drilling and producing oil and natural gas from an on-shore well
<b>dry steam plant</b>	power plant that relies on steam produced from a geothermal reservoir, but uses very little water in liquid form
<b>e</b> <b>elastic energy</b>	energy stored through the application of a force to stretch or compress an item

<b>electric charge</b>	either positive or negative, based on proton and electron interaction; electric charge determines the interaction of atoms with other atoms and produces electromagnetic fields
<b>electric current</b>	the flow of charged particles like electrons through a circuit, usually measured in amperes
<b>electric power</b>	see <i>power</i> ; the part of the economy related to generation of electricity
<b>electrical energy</b>	the energy associated with electric charges and their movements
<b>electricity</b>	a form of energy characterized by the presence and motion of elementary charged particles generated by friction, induction, or chemical change; electricity is electrons in motion
<b>electromagnetic</b>	having to do with magnetism produced by an electric current
<b>electromagnetism</b>	the interaction of forces occurring between electrically charged particles that can create an electric field or magnetic field
<b>electron</b>	a subatomic particle with a negative electric charge; electrons form part of an atom and move around its nucleus
<b>element</b>	the most pure form of matter; all matter is made of elements
<b>energy</b>	the ability to do work, produce change, or move an object; electrical energy is usually measured in kilowatt-hours (kWh), while heat energy is usually measured in British thermal units (Btu)
<b>energy carrier</b>	see <i>secondary source of energy</i>
<b>energy conservation</b>	changing a behavior or action with regards to energy use; riding a bike rather than driving a car
<b>energy consumption</b>	the use of energy as a source of heat or power or as a raw material input to a manufacturing process
<b>energy efficiency</b>	the ratio of energy input to output; energy transformations have varying levels of efficiency, depending on the forms of energy involved; efficiency can be increased with the incorporation or substitution of equipment
<b>Energy Efficiency Ratio (EER)</b>	rating used to help determine efficiency of appliances
<b>energy level</b>	area where electrons can be found; describes the probable amount of energy in the atom
<b>ENERGY STAR®</b>	a program that tests and certifies products based on efficiency features; labels help consumers save money
<b>EnergyGuide label</b>	a label on an appliance that shows how much energy the appliance uses in comparison to similar appliances
<b>ethanol</b>	a colorless liquid that burns to produce water and carbon dioxide; the vapor forms an explosive mixture with air and can be used as a fuel in internal combustion engines, usually blended with gasoline
<b>exploratory well</b>	a well drilled by energy companies in an effort to locate a source of fuel, or geothermal activity
<b>f</b> <b>F-gases</b>	synthetically sourced gases composed of bonded halogen and carbon atoms; these gases, also known as fluorinated gases, have a multitude of uses but can be harmful to the atmosphere
<b>feedstock</b>	a raw material that can be used as a fuel or processed into a different fuel or product
<b>fermentation</b>	changing of a sugar into an acid, gas, or alcohol with the presence of bacteria or yeast



<b>filament</b>	the fine metal wire in a light bulb that glows when heated by an electric current
<b>fish ladder</b>	installations at dams that allow fish to travel upstream, over the dam, to spawn
<b>fission</b>	the splitting of atomic nuclei; this splitting releases large amounts of energy and one or more neutrons; nuclear power plants split the nuclei of uranium atoms
<b>fossil fuels</b>	fuels (coal, oil, etc.) that result from the compression of ancient plant and animal life formed over hundreds of millions of years
<b>fuel cell</b>	a device used to generate electricity using hydrogen and oxygen, an electrolyte membrane, and catalysts
<b>fuel rods</b>	sealed metal tubes consisting of ceramic fuel pellets; these rods are bundled into assemblies for use in nuclear reactors
<b>fusion</b>	when the nuclei of atoms are combined or "fused" together; the sun combines the nuclei of hydrogen atoms into helium atoms in a process called fusion; energy from the nuclei of atoms, called "nuclear energy," is released from fusion
<b>g generator</b>	a device that turns motion energy into electrical energy; the motion energy is sometimes provided by an engine or turbine
<b>geoexchange system</b>	see <i>heat exchanger</i>
<b>geothermal energy</b>	the heat energy that is produced by natural processes inside the Earth; it can be taken from hot springs, reservoirs of hot water deep below the ground, or by breaking open the rock itself
<b>global warming</b>	an increase in the near surface temperature of the Earth; global warming has occurred in the distant past as the result of natural influences, but the term is most often used today to refer to the warming some scientists predict will occur as a result of increased man-made emissions of greenhouse gases
<b>gravitational potential energy</b>	energy of position or place
<b>greenhouse effect</b>	the trapping of heat from the sun by the atmosphere, due to the presence of certain gases; the atmosphere acts like a greenhouse
<b>greenhouse gases</b>	gases that trap the heat of the sun in the Earth's atmosphere, producing the greenhouse effect; the two major greenhouse gases are water vapor and carbon dioxide; lesser greenhouse gases include methane, ozone, chlorofluorocarbons, and nitrogen oxides
<b>grid</b>	the layout of an electrical distribution system
<b>h halogen</b>	element that will glow in certain combinations, often used in light bulbs or lamps
<b>heat exchanger</b>	any device that transfers heat from one fluid (liquid or gas) to another or to the environment
<b>hydrocarbon</b>	a compound made up of only hydrogen and carbon; hydrocarbons are found in many fossil fuels
<b>hydroelectric power plant</b>	a power plant that uses moving water to power a turbine generator to produce electricity
<b>hydrogen</b>	a colorless, odorless, highly flammable gaseous element; it is the lightest of all gases and the most abundant element in the universe, occurring chiefly in combination with oxygen in water and also in acids, bases, alcohols, petroleum, and other hydrocarbons
<b>hydropower</b>	energy that comes from moving water

**hydrothermal** referring to heated water, often used to describe steam generation

**i** **incandescent light bulb** a type of electric light in which light is produced by a filament heated by electric current

**industrial sector (of the economy)** the part of the economy having to do with the production of goods; the industrial sector is made up of factories, power plants, etc.

**insulation** a material or substance used to separate surfaces to prevent the transfer of electricity, thermal energy, or sound

**j** **jobbers** companies that handle wholesale distribution of oil and refined products to merchants, industries, and utilities

**k** **kilowatt** a unit of power, usually used for electric power or energy consumption (use); a kilowatt equals 1,000 watts

**kilowatt-hour (kWh)** a measure of electricity defined as a unit of work or energy, measured as 1 kilowatt (1,000 watts) of power expended for 1 hour; one kWh is equivalent to 3,412 Btu

**kinetic energy** the energy of a body which results from its motion

**l** **Law of Conservation of Energy** the law governing energy transformations and thermodynamics; energy may not be created or destroyed, it simply changes form, and thus the sum of all energies in the system remains constant

**light emitting diode (LED)** energy saving light bulb that generates light through the use of a semiconductor

**liquefied petroleum gas (LPG)** a group of hydrocarbon-based gases derived from crude oil refining or natural gas fractionation, including: ethane, ethylene, propane, propylene, butane, butylene, and others; for convenience of transportation, these gases are liquefied through pressurization

**load** the power and energy requirements of users on the electric power system in a certain area or the amount of power delivered to a certain location or item

**lumen** a unit of luminous flux used, for example, to measure the total amount of visible light emitted from a light bulb

**m** **magma** molten rock within the Earth

**magnet** any piece of iron, steel, etc., that has the property of attracting iron or steel

**magnetic field** the area of force surrounding a magnet

**mantle** the largest, middle layer of the Earth, composed of rock and magma

**mercaptan** an organic chemical compound that has a sulfur like odor that is added to natural gas before distribution to the consumer, to give it a distinct, unpleasant odor (smells like rotten eggs); this serves as a safety device by allowing it to be detected in the atmosphere, in cases where leaks occur

**methane** a colorless, flammable, odorless hydrocarbon gas ( $\text{CH}_4$ ), which is the major component of natural gas; it is also an important source of hydrogen in various industrial processes; methane is a greenhouse gas

**miles per gallon (MPG)** a measure of vehicle fuel efficiency; MPG is computed as the ratio of the total number of miles traveled by a vehicle to the total number of gallons consumed

**molecule** particles that normally consist of two or more atoms joined together; an example is a water molecule that is made up of two hydrogen atoms and one oxygen atom

**motion energy** the displacement of objects and substances from one place to another

<b>motor</b>	a mechanical device that converts electrical energy into motion energy
<b>n</b>	
<b>natural gas</b>	an odorless, colorless, tasteless, non-toxic, clean-burning fossil fuel; it is usually found in fossil fuel deposits and used as a fuel
<b>neutron</b>	neutrally charged particle within the nucleus of an atom
<b>Newton's Laws of Motion</b>	three physical laws that govern the force and motion interaction of all bodies, for example, the Law of Inertia
<b>nonrenewable</b>	fuels that cannot be easily made or replenished; we can exhaust nonrenewable fuels; uranium, propane, oil, natural gas, and coal are nonrenewable fuels
<b>nuclear energy</b>	energy stored in the nucleus of an atom that is released by the joining or splitting of the nuclei
<b>nucleus</b>	the core of the atom that houses positively charged protons and neutrally charged neutrons
<b>0</b>	
<b>offshore</b>	the geographic area that lies seaward of the coastline; in general, the coastline is the line of ordinary low water along with that portion of the coast that is in direct contact with the open sea or the line marking the seaward limit of inland water
<b>ohm (<math>\Omega</math>)</b>	the unit of resistance to the flow of an electric current
<b>Ohm's Law</b>	a mathematical relationship between voltage (V), current (I), and resistance (R) in a circuit; Ohm's Law states the voltage across a load is equal to the current flowing through the load times the resistance of the load ( $V = I \times R$ )
<b>oil</b>	a black, liquid fossil fuel found deep in the ground; the raw material that petroleum products are made from; gasoline and most plastics are made from oil
<b>organic</b>	material that is living or came from a once-living organism
<b>ozone</b>	also known as trioxxygen, this unstable gas is created when chemicals from human activities in the atmosphere react with sunlight; an ozone layer, however, in the atmosphere protects plants and animals from ultraviolet light (UV) exposure
<b>p</b>	
<b>passive solar home</b>	a means of capturing, storing, and using heat from the sun, without using specialized equipment
<b>payback period</b>	the length of time a person must use a more expensive, energy efficient appliance before it begins to save money in excess of the initial cost difference
<b>peak demand</b>	a period when many consumers want electricity at the same time; peak demand often takes place during the day, and may require additional generation by utilities to satisfy demand
<b>penstock</b>	a large pipe that carries moving water from the reservoir to a turbine generator in a hydropower plant
<b>petroleum</b>	generally refers to crude oil or the refined products obtained from the processing of crude oil (gasoline, diesel fuel, heating oil, etc.); petroleum also includes lease condensate, unfinished oils, and natural gas plant liquids
<b>photosynthesis</b>	the process by which green plants make food (carbohydrates) from water and carbon dioxide, using the energy in sunlight
<b>photovoltaic cell</b>	a device, usually made from silicon, which converts some of the energy from light (radiant energy) into electrical energy; another name for a solar cell
<b>pipeline</b>	a length of pipe that carries petroleum and natural gas from a refinery to the consumer

<b>plates</b>	pieces of the Earth's crust that shift and move slowly over time
<b>porous</b>	property of materials, including rocks, that describes the amount of pores or tiny spaces within the material
<b>potential energy</b>	the energy stored within a body
<b>power</b>	the rate at which energy is transferred; electrical energy is usually measured in watts; also used for a measurement of capacity
<b>power plant</b>	a facility where power, especially electricity, is generated
<b>prevailing wind</b>	wind that blows from one direction at a particular point on the Earth at most times
<b>propane</b>	a normally gaseous, straight-chain hydrocarbon; a colorless, paraffinic gas that boils at a temperature of -43.67 degrees Fahrenheit; it is extracted from natural gas or refinery gas streams
<b>proton</b>	positively charged particle within the nucleus of the atom
<b>r</b> <b>radiant energy</b>	any form of energy radiating from a source in electromagnetic waves
<b>radiation</b>	any high-speed transmission of energy in the form of particles or electromagnetic waves
<b>radioactive (decay)</b>	a natural process where atoms give up energy and particles to become stable; radioactive waste from a power plant has not yet become stable and, thus, can be harmful
<b>reactor</b>	part of a nuclear power station—the structure inside which fission occurs in millions of atomic nuclei, producing huge amounts of heat energy
<b>reclaimed</b>	land that was once used by industry (mining, drilling) and has been restored to original conditions/habitats, or as close to original condition as possible
<b>recycling</b>	the process of converting materials that are no longer useful as designed or intended into a new product
<b>refinery</b>	an industrial plant that heats crude oil (petroleum) so that it is separated into chemical components, which are then made into more useful substances
<b>renewable</b>	fuels that can be easily made or replenished; we can never use up renewable fuels; types of renewable fuels are hydropower (water), solar, wind, geothermal, and biomass
<b>repository</b>	a housing for spent nuclear fuel
<b>reserves</b>	natural resources that are technically and economically recoverable
<b>reservoir</b>	natural or artificial storage facility
<b>residential sector (of the economy)</b>	the part of the economy having to do with the places people stay or live; the residential sector is made up of homes, apartments, condominiums, etc.
<b>resistance</b>	a measure of the amount of energy per charge needed to move a charge through an electric circuit, usually measured in ohms
<b>Ring of Fire</b>	a region of high geothermal activity in the Pacific Ocean, located along several plate boundaries



<b>S</b>	<b>scrubber</b>	air pollution control device that power plants use to remove particulate matter and gases from their emissions
	<b>secondary source of energy</b>	also known as energy carriers, these sources require another source of energy to be created; electricity is an example of a secondary source of energy
	<b>sedimentary</b>	a type of rock formed by deposits of earth materials, or within bodies of water; oil and gas formations, as well as fossils are found within sedimentary rock formations; coal is a sedimentary rock
	<b>silicon</b>	element commonly used for semiconductors and in electric components
	<b>siting</b>	the multi-step process of determining the best location for wind turbines
	<b>smelting</b>	producing a metal from its ore, separating the metallic parts of an ore
	<b>solar cell</b>	an electric cell that changes radiant energy from the sun into electrical energy by the photovoltaic process
	<b>solar collector</b>	an item, like a car or greenhouse, that absorbs radiant energy from the sun and traps the energy within it as thermal energy
	<b>solar energy</b>	the radiant energy of the sun, which can be converted into other forms of energy, such as thermal energy or electricity
	<b>sound energy</b>	energy that travels in longitudinal waves
	<b>space heating</b>	heating the interior of a building or home
	<b>spent fuel</b>	irradiated fuel that is permanently discharged from a nuclear reactor
	<b>spillway gate</b>	a gate or apparatus at a dam that helps to control the water level of a reservoir; gates release excess water following heavy rainfall
	<b>substation</b>	equipment located along transmission lines that lowers voltage
	<b>surface mining</b>	takes place within a few hundred feet of the surface; earth above or around the coal (overburden) is removed to expose the coal bed, which is then mined with surface excavation equipment
	<b>sustainable</b>	describing a behavior or practice that is capable of being continued with minimal effects on the environment
<b>t</b>	<b>thermal energy</b>	the total potential and kinetic energy associated with the random motions of the atoms and molecules of a material; the more the molecules move and vibrate the more energy they possess
	<b>thermostat</b>	a device that adjusts the amount of heating and cooling produced and/or distributed by automatically responding to the temperature in the environment
	<b>transformer</b>	a device that converts the generator's low-voltage electricity to higher-voltage levels for transmission to the load center, such as a city or factory
	<b>transmission line</b>	a set of conductors, insulators, supporting structures, and associated equipment used to move large quantities of power at high voltage, usually over long distances between a generating or receiving point and major substations or delivery points
	<b>turbine</b>	a device with blades, which is turned by a force, e.g., that of wind, water, or high pressure steam; the motion energy of the spinning turbine is converted into electricity by a generator

**transportation sector (of the economy)** the part of the economy having to do with how people and goods are transported (moved) from place to place; the transportation sector is made up of automobiles, airplanes, trucks, ships, trains, etc.

**U** **underground (deep) mining** coal mining that takes place several hundred feet below the surface of the earth; workers and coal enter and exit through a vertical shaft

**uranium** a heavy, naturally-occurring, radioactive element

**V** **volt (V)** the International System of Units (SI) measure of electric potential or electric force

**voltage** the difference in electric potential between any two conductors or between a conductor and the ground; it is a measure of the electrical energy per electron that electrons can acquire and/or give up as they move between the two conductors

**W** **waste-to-energy plant** a power plant that generates electricity by burning garbage

**watt** a metric unit of power, usually used in electric measurements, which gives the rate at which work is done or energy used

**watt-hours** a measure of electrical energy consumed

**well** a hole drilled in the Earth for the purpose of finding or producing crude oil or natural gas, or producing services related to the production of crude oil or natural gas

**wind** the term given to any natural movement of air in the atmosphere; a renewable source of energy used to turn turbines to generate electricity

**wind farm** a series or group of wind turbines in one location

**wind turbine** device powered by the wind that produces motion or electric power

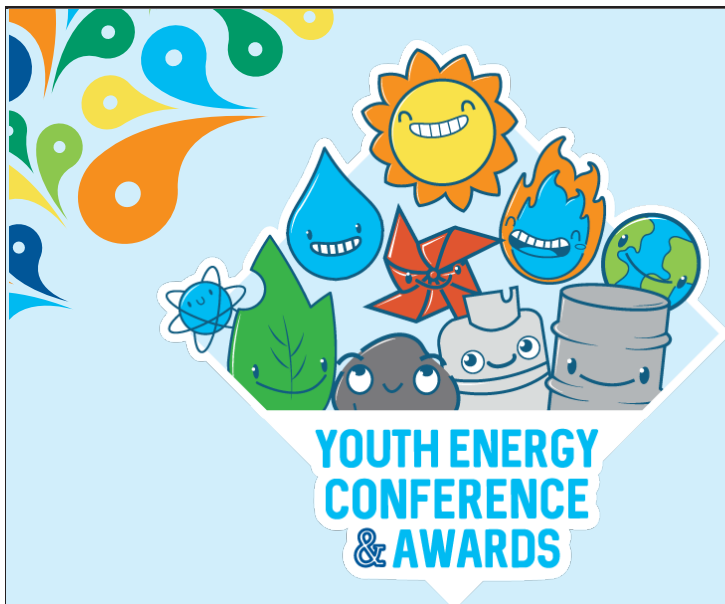

## YOUTH ENERGY CONFERENCE AND AWARDS

The NEED Youth Energy Conference and Awards gives students more opportunities to learn about energy and to explore energy in STEM (science, technology, engineering, and math). The annual June conference has students from across the country working in groups on an Energy Challenge designed to stretch their minds and energy knowledge. A limited number of spaces are available for a special two-day pre-conference event, which allows students access to additional information, time to discuss energy with their peers, and access to industry professionals. The conference culminates with the Youth Awards Ceremony recognizing student work throughout the year and during the conference.

**For More Info:** <http://tinyurl.com/youthenergyconference>

## YOUTH AWARDS PROGRAM FOR ENERGY ACHIEVEMENT

**All NEED schools have outstanding classroom-based programs in which students learn about energy. Does your school have student leaders who extend these activities into their communities? To recognize outstanding achievement and reward student leadership, The NEED Project conducts the National Youth Awards Program for Energy Achievement.**

### **Share Your Energy Outreach with The NEED Network!**

This program combines academic competition with recognition to acknowledge everyone involved in NEED during the year—and to recognize those who achieve excellence in energy education in their schools and communities.

### **What's involved?**

Students and teachers set goals and objectives and keep a record of their activities. Students create a digital project to submit for judging. In April, digital projects are uploaded to the online submission site.

Want more info? Check out [www.NEED.org/Youth-Awards](http://www.NEED.org/Youth-Awards) for more application and program information, previous winners, and photos of past events.

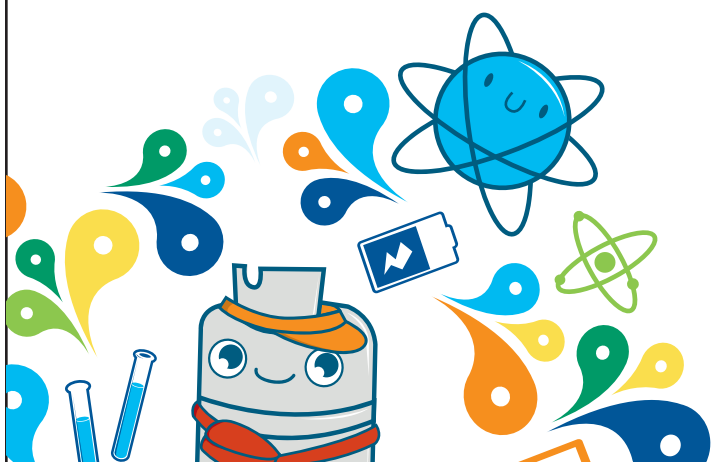



# National Sponsors and Partners

Air Equipment Company  
Alaska Electric Light & Power Company  
Albuquerque Public Schools  
American Electric Power  
American Fuel & Petrochemical Manufacturers  
Arizona Public Service  
Armstrong Energy Corporation  
Barnstable County, Massachusetts  
Robert L. Bayless, Producer, LLC  
BG Group/Shell  
BP America Inc.  
Blue Grass Energy  
Cape Light Compact–Massachusetts  
Central Falls School District  
Chugach Electric Association, Inc.  
CITGO  
Clean Energy Collective  
Colonial Pipeline  
Columbia Gas of Massachusetts  
ComEd  
ConEdison Solutions  
ConocoPhillips  
Constellation  
Cuesta College  
David Petroleum Corporation  
Desk and Derrick of Roswell, NM  
Direct Energy  
Dominion Energy  
Donors Choose  
Duke Energy  
East Kentucky Power  
Energy Market Authority – Singapore  
Escambia County Public School Foundation  
Eversource  
Exelon Foundation  
Foundation for Environmental Education  
FPL  
The Franklin Institute  
George Mason University – Environmental Science and Policy  
Gerald Harrington, Geologist  
Government of Thailand–Energy Ministry  
Green Power EMC  
Guilford County Schools – North Carolina  
Gulf Power  
Hawaii Energy  
Idaho National Laboratory  
Illinois Clean Energy Community Foundation  
Illinois Institute of Technology  
Independent Petroleum Association of New Mexico  
James Madison University  
Kentucky Department of Energy Development and Independence  
Kentucky Power – An AEP Company  
Kentucky Utilities Company  
League of United Latin American Citizens – National Educational Service Centers  
Leidos  
Linn County Rural Electric Cooperative  
Llano Land and Exploration  
Louisville Gas and Electric Company  
Mississippi Development Authority–Energy Division  
Mississippi Gulf Coast Community Foundation  
Mojave Environmental Education Consortium  
Mojave Unified School District  
Montana Energy Education Council  
The Mountain Institute  
National Fuel  
National Grid  
National Hydropower Association  
National Ocean Industries Association  
National Renewable Energy Laboratory  
NC Green Power  
New Mexico Oil Corporation  
New Mexico Landman’s Association  
NextEra Energy Resources  
NEXTracker  
Nicor Gas  
Nisource Charitable Foundation  
Noble Energy  
Nolin Rural Electric Cooperative  
Northern Rivers Family Services  
North Carolina Department of Environmental Quality  
North Shore Gas  
Offshore Technology Conference  
Ohio Energy Project  
Opterra Energy  
Pacific Gas and Electric Company  
PECO  
Pecos Valley Energy Committee  
Peoples Gas  
Pepco  
Performance Services, Inc.  
Petroleum Equipment and Services Association  
Phillips 66  
PNM  
PowerSouth Energy Cooperative  
Providence Public Schools  
Quarto Publishing Group  
Read & Stevens, Inc.  
Renewable Energy Alaska Project  
Rhode Island Office of Energy Resources  
Robert Armstrong  
Roswell Geological Society  
Salt River Project  
Salt River Rural Electric Cooperative  
Saudi Aramco  
Schlumberger  
C.T. Seaver Trust  
Secure Futures, LLC  
Shell  
Shell Chemicals  
Sigora Solar  
Singapore Ministry of Education  
Society of Petroleum Engineers  
Society of Petroleum Engineers – Middle East, North Africa and South Asia  
Solar City  
David Sorenson  
South Orange County Community College District  
Tennessee Department of Economic and Community Development–Energy Division  
Tesla  
Tesoro Foundation  
Tri-State Generation and Transmission  
TXU Energy  
United Way of Greater Philadelphia and Southern New Jersey  
University of Kentucky  
University of Maine  
University of North Carolina  
University of Tennessee  
U.S. Department of Energy  
U.S. Department of Energy–Office of Energy Efficiency and Renewable Energy  
U.S. Department of Energy–Wind for Schools  
U.S. Energy Information Administration  
United States Virgin Islands Energy Office  
Wayne County Sustainable Energy  
Western Massachusetts Electric Company  
Yates Petroleum Corporation